

FEATURES

MAC-A / MAC-C

Utility form-finisher ideal for the finishing of coats, jackets, dresses, etc.

Automated working cycles.

Electronic card.

Possibility to set nine different cycles, and regulation of steaming and drying time.

Adjustable shoulder width and height of the dummy.

Rotation 360° of dummy support (frame) and controls.

MAC-C (without boiler)

Without steam boiler, to be connected to a central steam supply.

It needs a steam inlet and outlet.

Can be installed with steam generator SB-24 - 12 kW.

Voltage: 230V III / 400V III 50Hz.

MAC-A (with boiler)

Complete with built-in steam boiler 18 lt.

Automatic water feeding.

Automatic pressure control (4,5 bar).

Voltage: 230V III / 400V III 50Hz.

TOPPER-A / TOPPER C

Finishing topper for trousers, with air-operated waistband and leg stretching devices.

Side waistband stretching device.

Height adjustable leg stretching carriage and stainless steel leg clamps.

Built-in three-phase fan; air heating device.

Electronic card for the setting of nine ironing cycles in total.

Ironing cycle controlling: steaming time, steam/air time, drying time. Three pressure regulators (for leg clamps, waistband stretcher and leg stretching carriage).

Switch for the exclusion of the leg stretching carriage.

Manual size indicator.

Mechanical airflow regulator.

TOPPER-C (without boiler)

Without boiler.

Needs connection to external steam source.

Can be connected to SB-24 steam generator.

TOPPER-A (with boiler)

With built-in boiler.

Electric operation.



GENERAL DETAILS	UNIT.	TOPPER-C
Boiler	-	NO
Boiler capacity	L	-
Group of iron	-	-
Steam gun	-	-
POWER		
Pump motor	HP	-
Boiler heater	kW	-
Fan motor	kW	1-1,5
CONNECTIONS		
Ø Water inlet	BSP	-
Ø Boiler exhaust (mod. with boiler)	BSP	-
Ø Steam inlet	BSP	3/8"
Ø Condensate outlet	BSP	3/8"
Steam pressure	BAR	5
Steam consumption	Kg/h	15-20
Ø Air inlet	BSP	1/4"
Ø Air outlet	mm	-
Air pressure	BSP	5
Air Consumption	NI/min	40
DIMENSIONS / PACKING DIMENSIONS		
Net width / Gross width	mm	1.115 / 1.210
Net depth / Gross depth	mm	630 / 780
Net height / Gross height	mm	1.950 / 2.100
Net weight / Gross weight	kg	119 / 175
Volume	m ³	1,37 / 1,98
OTHERS		
Voltage	V/Hz	230/400V III 50-60
Sound level	dB	70

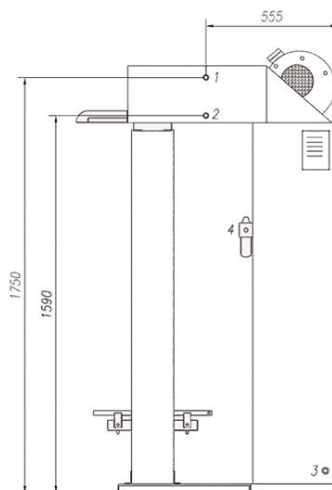
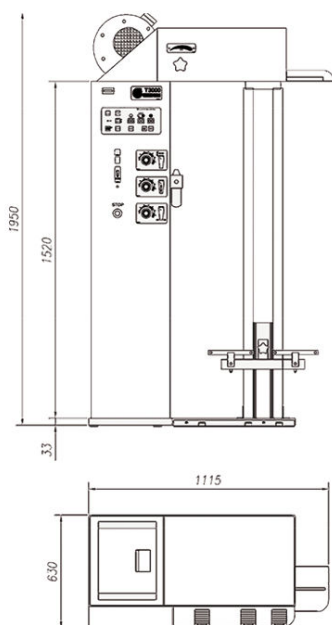

1. Steam inlet
2. Condensate purge
3. Inlet electrical power
4. Compressed air inlet