

TOUCH II

- TOUCH II: Easy-to-use microprocessor, fully programmable with a 7" touchscreen.
- USB port: configure, update, and analyse machines without internet connection.
- On-screen videos: add your logo, video advertisements or instructions for use (useful for self-service).
- Multilingual interface.
- 8 standard dosing signals and 6 extra as an option.

G FACTOR

High G-factor of 500 (11-18 kg), 450 (22-80 kg), and 350 (100-120 C).
Reduces residual moisture

EFFICIENCY

Optimal loading: manual indication of weight.
Intelligent consumption: automatic adjustment of water and soap consumptions (standard).
Water Recovery tanks ready: **ECOTANK** and **ECOTANK XL**.
Low water consumption.

VERSATILITY

Make to order: customisation.
OPL < > COIN (mod. DHS-11 up to DHS-45C).
Electric < > Hot water.
Drain valve < > Pump (DHS-11/14).
Wet Cleaning features.

CONNECTIVITY

IoT - **DOMUSCONNECT** standard.
Remote technical service.
Management for laundries: OPL and COIN.
Remote payment DOMUS LAUNDRY App (mod. DHS-11 up to DHS-45C).

ERGONOMICS

Easy opening/closing system for door lock.
Biggest door diameters:

- Ø 373 (11, 14 kg)
- Ø 460 (18, 22, 28 kg)
- Ø 560 (35, 45, 60, 80 kg)
- Ø 700 (100, 120 kg)

MAINTENANCE

Hinged control panel: easy and ergonomic access.
Technical menu: statistics for technicians.

OTHERS

Grey skinplate outer casing.
Drum and vat in stainless steel AISI 304.
Detergent dispenser with 4 compartments.
Electronic control of imbalance with frequency control.
LOADING AID feature: water and rotation control.
Soft mounted washers, free standing.
CB and WRAS approved product. Option ETL.
REG4 standard certified by KIWA.



OPTIONS

- License IoT - DOMUSCONNECT
- Ready for ECOTANK XL conn. 1" for washers DHS-100C/120C
- DOSING PUMP KIT DQ-2
- EXTRA DOSING PUMP DB-1
- Double drain kit for DHS-100C/120C
- Kit watermark Australia
- Double tilt for DHS-100C/120C- Available with weighing system
- Front tilt for DHS-100C/120C - Available with weighing system
- Weighing sensor system on feet for DHS-60C/80C/100C/120C - Available with tilt systems
- 6 extra dosing signals card for DHS-60C/80C/100C/120C
- Reversible door: reverse door opening
- Steam kit DHS-100C/120C
- Stainless steel AISI 304 outer casing for DHS-120C
- 440V 3~ (No N) 50/60 Hz DHS-100C/120C (marine)
- 230V 3~ 50/60Hz DHS-100C/120C

TECHNICAL DATA	UNIT.	DHS-120C TOUCH II
DRUM		
Load capacity 1:9 / 1:10	Kg	130/115
Volume	l	1150
	gal	303,7
Diameter	mm	1360
	inch	53,5
Depth	mm	775
	inch	30,5
GENERAL DATA		
Washing speed / Spin speed	r.p.m.	34/678
G factor	-	350
Maximum transmitted force	KN	37,77 ±5,25
Dynamic force frequency	Hz	11,33
Sound level	dB	< 70
Self-service version	-	NO
Double drain	-	OPT.
Weighing system / Tilting system	-	OPT.
SLUICE option	-	NO
DOOR		
Door centre height / Door base height	mm	1.330 / 900
	inch	52,3"/35,4"
Diameter	mm	700
	inch	27,5"
POWER		
Motor	kW	15
Electric heating (electric model)	kW	-
Maximum electric power	kW	-
Max. power steam & hot water model	kW	15
CONNECTIONS		HW/S
Voltage 110V - 1 + N + E	Nº x mm2 / A	-
	Nº x AWG / A	-
Voltage 230V - 1 + N + E	Nº x mm2 / A	-
	Nº x AWG / A	-
Voltage 230V - 3 + E	Nº x mm2 / A	4x16 / 63A
	Nº x AWG / A	4x5 / 70A
Voltage 400V - 3 + N + E	Nº x mm2 / A	5x6 / 40A
	Nº x AWG / A	5x9 / 45A
Steam inlet (steam model)	inch	1-1/4"
Max. steam consumption (steam model)	Kg/h	26,5
Water inlet	inch	1-1/2"
Water pressure	Kgs/cm2	2-4
Max. water consumption*	Lit/h	1254**
	GPH	331,2**
Drain	mm/inch	4"
Drain capacity	Lit/min	500
	GPM	132
DIMENSIONS / PACKED DIMENSIONS		
Net width / Gross width	mm	1.836 / 1.940
	inch	72,2"/76,3"
Net depth / Gross depth	mm	1.832 / 2.030
	inch	72,1"/79,9"
Net height / Gross height	mm	2.245 / 2.290
	inch	88,3"/90,1"
Net weight / Gross weight	kg	2.762 / 3.058
	lb	6089,1/6741,7

Packing volume	m3	9
	ft3	317,8

Programme no.20, 75% load

**Programme no.2, 100% load

*** 400V version = 48kW / 230V = 36kW

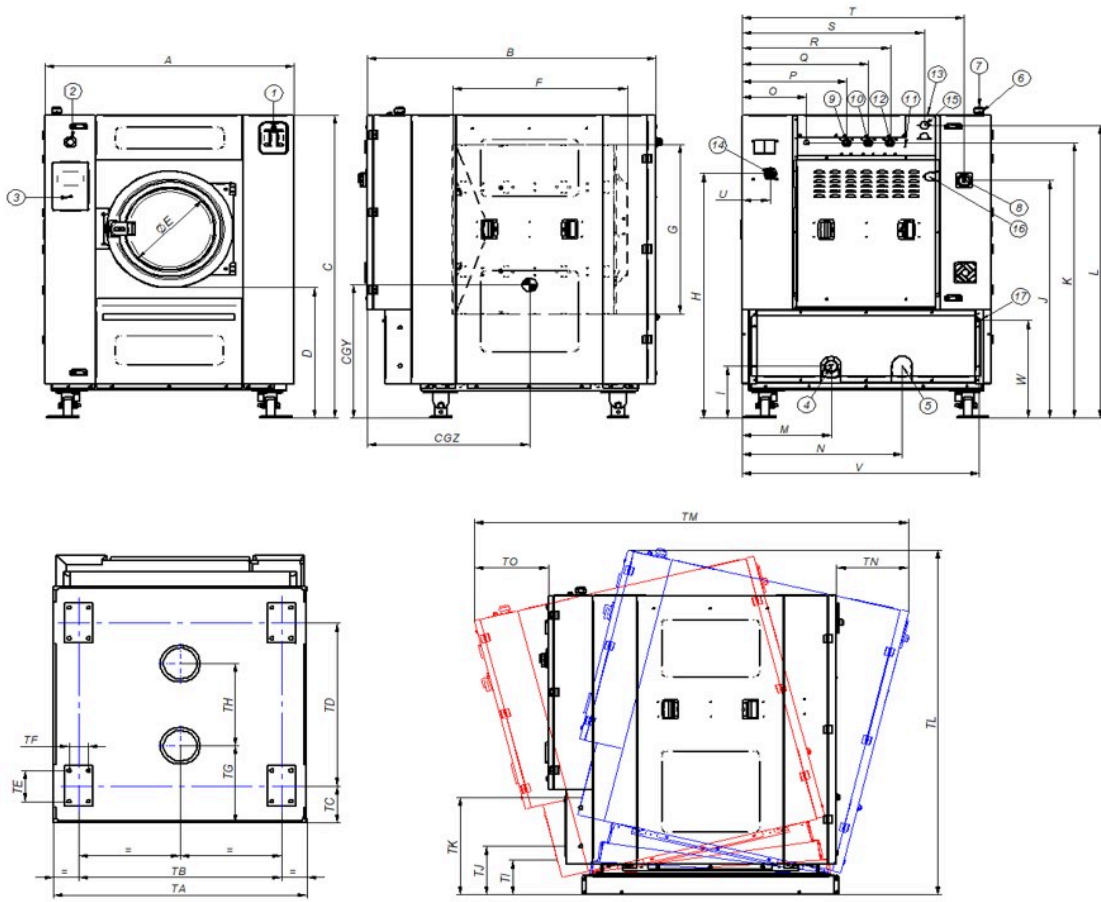

1. Soap dispenser
2. Emergency stop
3. USB port
4. Drain 1
5. Drain 2
6. Electric connection to liquid soap pumps
7. Electrical connection
8. Main switch
9. Auxiliar water inlet
10. Hot water inlet
11. Equipotential connection
12. Cold water inlet
13. Steam output
14. Liquid soap connection
15. Steam connection
16. Air intake
17. Ethernet port

		A	B	C	D	E	F	G	H	I	J	K	L	M	N	O	P	Q	R	S	T	U	V	W	Y	Z	CGY	CGZ
DHS-100C	mm	1836	1710	2245	945	700	792	1350	1740	336	1781	2038	2110	1095	1092	494	634	774	954	994	1239	1646	165	2049	2050	717	853	1025
DHS-120C	mm	1836	1832	2245	945	700	930	1350	1740	336	1781	2038	2110	1095	1092	494	634	774	954	994	1239	1646	165	2049	2050	717	853	1130
		TA	TB	TC	TD	TE	TF	TG	TH	TI	TJ	TK	TL	TM	TN	TO												
DHS-100C	mm	1765	1615	200	1161	190	110	375	806	210	330	667	2504	2636	496	491												
DHS-120C	mm	1765	1615	200	1344	190	110	375	990	254	330	662	2465	2672	419	423												