

TOUCH II

User friendly and totally programmable microprocessor with 7" touch screen.
 USB Connection.
 Online platform free of charge for programming, telemetry, data analysis...thanks to the IoT.
 Videos shown on display: ads, instructions (useful for coin laundry).
 37 languages.

OUTSTANDING FEATURES

Reversing drum action as standard.
 Stainless steel drum as standard.
 Frequency inverter as standard.

EFFICIENCY

EFFICIENT DRY - Intelligent humidity control, with new drum inlet temperature control.
 AIR RE-CYCLE - Efficient air recirculation system.
 THERMAL INSULATION - Complete air-flow circuit and double door glass.
 FULL FLOW - Optimized system with mixed airflow.
 Big fluff filter.

VERSATILITY

Make to order - customisation.
 Wet Cleaning.

CONNECTIVITY

Standard IoT **DOMUSCONNECT**.
 Management for laundries: OPL and self-service.

ERGONOMICS

Drawer as fluff filter, stainless steel mesh.
 Biggest door diameters.
 Opening sense of door adjustable on site.

MAINTENANCE

Hinged control panel: easy and ergonomic access.
 Technical menu: statistics for technicians.

OTHERS

Grey skinplate outer casing, stainless steel look.
NEW: Geared motor drive on models DTT-45 to DTT-80
 SFEX - Integrated Fire Extinguishing System.
 SOFT DRY - new drum with stamped holes.
 COOL DOWN - anti-wrinkle at the end of the cycle.
 Heating options: electric, gas and steam.
 CE approved



OPTIONS

- License IoT - DOMUSCONNECT
- Automatic sliding door DTT-45/60/80 (double glass)
- Natural gas heated tumble dryer
- Manual sliding door DTT-45/60/80 (no double glass)
- Tilting front kit DTT-45/60/80
- Opposite door opening DTT-45/60/80
- Tropicalized model
- Dosing spraying of perfume
- Back panel with air filter DTT-45/60/80
- Fluff filter with grid 0,6mm (standard is 0,3mm)
- Fluff filter with grid 1,2mm (standard is 0,3mm)
- Stainless steel front and side panels DTT-60
- Front panel in stainless steel DTT-45/60/80
- Low pressure steam battery DTT-45/60/80
- Maritime wooden packing DTT-60
- 230V III 50Hz DTT-45/60/80 E
- 230V III 60Hz DTT-45/60/80 E
- 400V III 60Hz DTT-45/60/80 E/S
- 400V III 60Hz DTT-45/60/80 G
- 230V III 50Hz DTT-45/60/80 G/S
- 230V III 60Hz DTT-45/60/80 S
- 230V III 60Hz DTT-45/60/80 G
- 400V III 50Hz DTT-60/80
- 440/480V III 60Hz DTT-45/60/80

CAPACITY & DRUM	UNIT.	DTT-60 ECO-ENERGY
Capacity 1/18	Kg	66,7
	lb	146,9
Capacity 1/20	Kg	60
	lb	132,3
Ø Drum	mm	1.225
	inch	48,23
Drum length	mm	1.020
	inch	40,16
Drum volume	l	1.200
	cu ft	42,37
Ø Door hole	mm	802
	inch	31,57
Door center height	mm	1.275
	inch	50,20
Height from floor to bottom of door	mm	813
	inch	31,99
ELECTRIC HEATING		
Evaporation capacity	L/h	64
	US gallon/h	16,91
Hourly output	Kg/h	128,60
	lb/h	283,5
Installed heating power	kW	72
Installed electrical power	kW	75,35
Drum motor power	kW	1,10
GAS HEATING		
Evaporation capacity (gas model)	L/h	72
	US gallon/h	19,020
Hourly output (gas model)	Kg/h	144
	lb/h	317,5
Installed gas heating power	kcal/h	77386
	Btu/h	307092,7
Installed gas heating power	kW	90
Installed electrical power	kW	3,35
Instant propane gas consumption (G31)	Kg/h	7,71
	lb/h	17
Instant natural gas consumption (G20)	m ³ /h	9,53
	cfm	5,61
Ø Gas inlet	BSPP ISO 228-1	3/4"
STEAM HEATING		
Installed steam heating power	kW	128
	Btu/h	436754
Installed electrical power	kW	3,35
Steam consumption (8 barG) - Standard	kg/h	171
Steam consumption (116 psiG)	lb/h	206
Steam pressure	barG	7 - 12
	psiG	101,5 - 177
Standard steam inlet - outlet	BSPT- ISO7.1	1"
Standard steam inlet - outlet	NPT ANSI B1.20.1 Tapered	1"
Steam consumption (5 barG) - Low Pressure	kg/h	147
Steam consumption (72,5 psiG) - Low Pressure	lb/h	177,1
Steam pressure (low pressure)	barG	4 - 7
	psiG	58 - 101,5
Low pressure steam inlet - outlet	BSPT- ISO7.1	1" 1/2
THERMAL OIL HEATING		
Installed heating power	kW	128
Installed electrical power	kW	3,35
Fluid consumption (T max 175°C)	m ³ /h	10

Thermal oil connection	BSP	1" 1/2	
VENTILATION			
Fan motor power	kW	2,20	
Nominal air flow rate	m ³ /h	4.500	
	cfm	2648,60	
Ø Fume exhaust	mm	300	
	inch	11,81	
HEAT EMISSION			
Maximum total heat emission	kW	5,04	
	Btu/h	17207,3	
Max. front heat emission	kW	1,44	
	Btu/h	4916,4	
CONNECTIONS			
Tension 230V - I + N + T	Nº x mm ² / A	-	-
Tension 230V - III + T	Nº x mm ² / A	-	4 x 2,5 / 25A
Tension 400V - III + N + T	Nº x mm ² / A	5 x 50 / 125A	5 x 2,5 / 25A
NET DIMENSIONS / D. WITH PACKING			
Net / gross width	mm	1.270 / 1.330	
	inch	50 / 52,36	
Net / gross depth	mm	1.366 / 1.455	
	inch	53,78 / 57,28	
Net height / gross height	mm	2.380 / 2.200	
	inch	93,70 / *86,61	
Net / gross weight	Kg	529 / 575	
	lb	1.166,25 / 1.267,66	
OTHERS			
Sound level	dB	67	

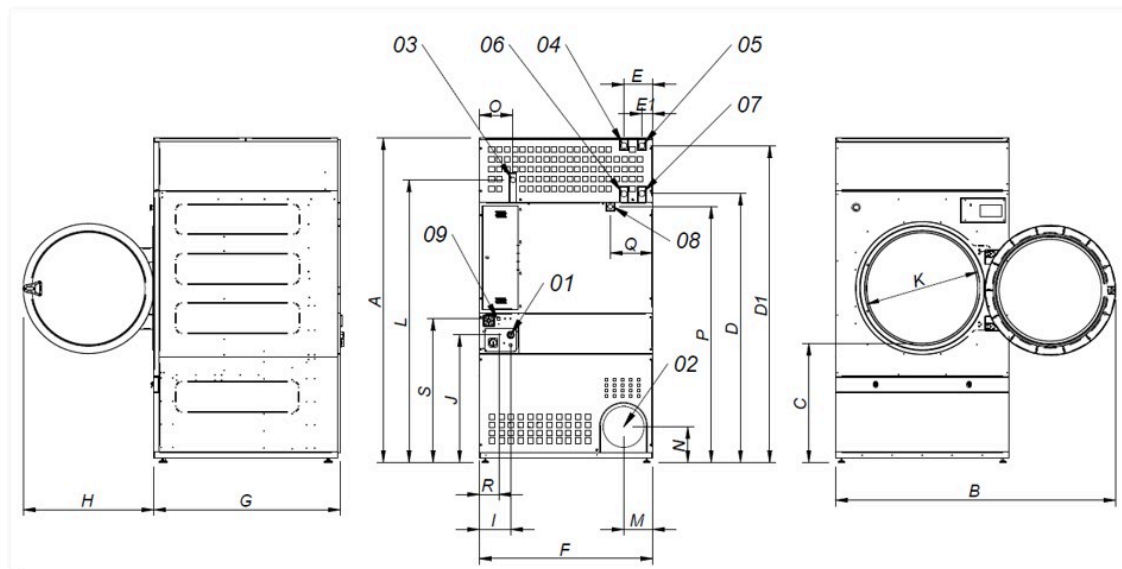

- 01 Power supply
- 02 Fumes output Ø 300
- 03 Gas inlet 1/2"
- 04 Steam inlet 1" (DTT-45)
- 05 Steam inlet 1" (DTT-60-80)
- 06 Condensate outlet 1" (DTT-45)
- 07 Condensate outlet 1" (DTT-60-80)
- 08 Sprinkler valve 3/4"
- 09 Ethernet connection (only TOUCH Control)

	A	B	C	D	D1	E	E1	F	G	H	I	J	K	L	M	N	O	P	Q	R	S
DTT-45 ECO-ENERGY	2.380	2.045	874	1.981	2.311	211	80	1.270	1.106	956	248	935	802	2.088	214	240	244	1.841	308	160	1.053
DTT-60 ECO-ENERGY	2.380	2.045	874	1.981	2.311	211	80	1.270	1.366	956	248	935	802	2.088	214	240	244	1.841	308	160	1.053
DTT-80 ECO-ENERGY	2.380	2.045	874	1.981	2.311	211	80	1.270	1.598	956	248	935	802	2.088	214	240	244	1.841	308	160	1.053