

TOUCH II

User friendly and totally programmable microprocessor with 7" touch screen.
 USB Connection: PC software free of charge for programming, telemetry, data analysis, etc.
 Videos on display: ads, instructions (useful for coin laundry). 37 languages.
 8 dosing signals as standard.

G FACTOR

G FACTOR 200: 11 - 45 kg.
 G FACTOR 150: 60 - 80 kg.

EFFICIENCY

Intelligent consumption: automatic adjustment of water and soap consumptions (standard).
 Optimal loading: manual indication of weight.
 Low water consumption.

VERSATILITY

Make to order: customisation.
 OPL < > Self-service.
 Electric < > Hot water.
 Wet Cleaning features.

CONNECTIVITY

IoT - **DOMUSCONNECT** standard.
 Remote technical service.
 Management of laundries: self-service & OPL.
 Remote payment.

ERGONOMICS

Easy opening/closing system for door lock.
 Biggest door diameters:

- Ø 373 (11, 14 kg)
- Ø 460 (18, 22 y 28 kg)
- Ø 560 (35, 45, 60, 80 kg)

MAINTENANCE

Hinged control panel: easy and ergonomic access.
 Technical menu: statistics for technicians.
 Equivalent parts for all models: electronic parts, contactors.

OTHERS

Hard mounted washers.
 Anchoring to floor with anchoring base.
 Panels in skinplate.
 Drum and vat in stainless steel AISI 304.
 3 water inlets.
 CB and WRAS approved product. Option ETL.
 REG4 standard certified by KIWA.



OPTIONS

- License IoT - DOMUSCONNECT
- Ready for ECOTANK conn. 3/4" for washers DLS/DHS-11/14/18/22/28
- DOSING PUMP KIT DQ-2
- EXTRA DOSING PUMP DB-1
- Normally closed valve DLS-18/22
- SLUICE - Drum with 8 mm holes for DLS-18
- Anchoring base for DLS-18
- Double drain kit for DLS-18/22/28/35C/45C
- Normally closed valve DLS-18/22
- Water recycle DLS-18/22
- 6 extra dosing signals card for DLS-11 to DLS-45C
- Silicon gasket DLS-18/22/28
- Reversible door: reverse door opening
- Tropicalized model: protected board (TOUCH II)
- Kit to transform an E or HW for DLS-11/14/18/22 to steam
- Stainless steel AISI 304 outer casing for DLS-18
- Stainless steel AISI 304 top and front panel for DLS-18
- 440V III No N 50/60Hz DLS-18/22
- KIT 110/230V 1,2KV DLS-11/14/18
- Auto unlock kit for the door (in case of power failure) DLS-DHS
- Several payment systems for self-service

DRUM	UNIT.	DLS-18 TOUCH II	
Capacity 1/9	Kg	20	
Capacity 1/10	Kg	18	
Volume	l	180	
Diameter	mm	700	
Depth	mm	470	
GENERAL DETAILS			
Washing speed / Spining speed	r.p.m.	50 / 714	
G Factor	-	200	
Maximum force transmitted	KN	2,63 ±5	
Frequency-dynamic force	Hz	8,42	
Noise level	dB	< 70	
Coin laundry version	-	YES	
Double drain	-	OPT.	
Weighing system / Tilting door	-	NO	
SLUICE option	-	YES	
DOOR			
Height center door / Height door	mm	655 / 348	
Diameter	mm	460	
POWER			
Motor	kW	2,2	
Electric heating power	kW	12	
Total electric power (electric model)	kW	12,75	
Total electric power (hw, steam model)	kW	2,2	
CONNECTIONS		E	HW/S
Tension 110V - I + N + T	Nº x mm ² / A	-	-
Tension 230V - I + N + T	Nº x mm ² / A	2x16+T - 63A	2x1,5+T - 16A
Tension 230V - III + T	Nº x mm ² / A	3X6+T - 40A	-
Tension 400V - III + N + T	Nº x mm ² / A	4x4+T - 32A	-
Steam inlet (Steam model)	inch	1/2"	1/2"
Maximum steam consumption (Steam model)	Kg/h	12	
Water inlet	inch	3/4"	
Water main pressuer	Kgs/cm ²	2-4	
Maximum water consumption*	Lit/h	120*	
Drain	mm/inch	3"	
Drainage capacity	Lit/min	200	
DIMENSIONS / PACKING DIMENSIONS			
Net Width/Gross width	mm	788 / 850	
Net Depth/Gross depth	mm	935 / 1.013	
Net Height / Gross height	mm	1.307 / 1.583	
Net weight / Gross weight	kg	272 / 309	
Volume	m ³	1,36	

* Program No. 20: DLS-11 to DLS-45C with 75% load and program no. 2: DLS-60C and DLS-80C with 100% load

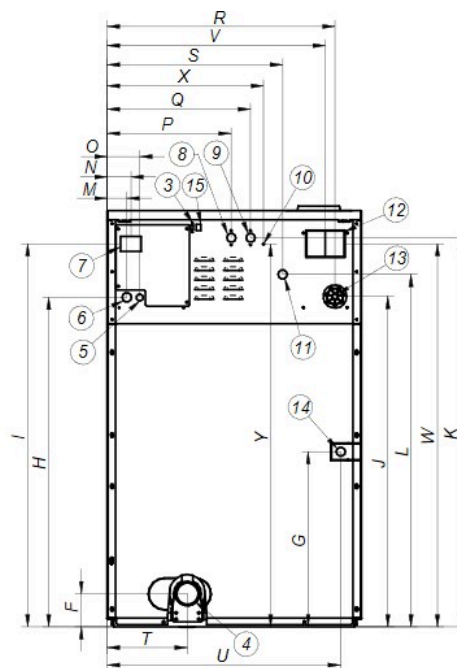
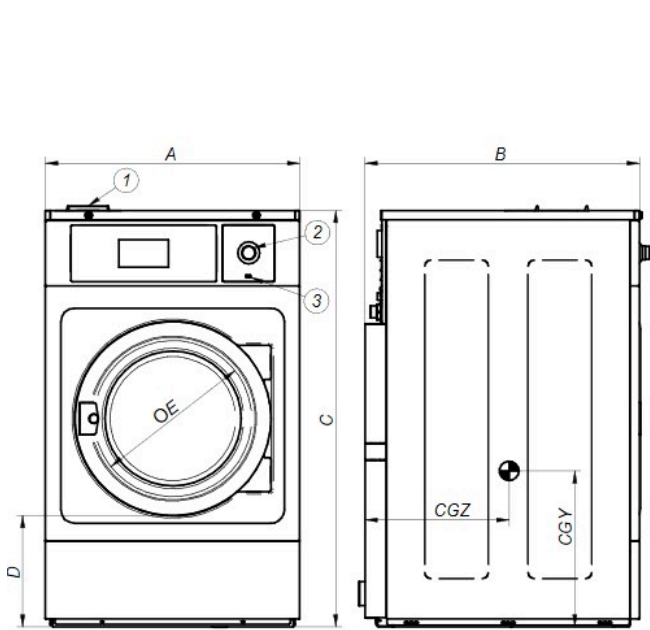

1. Soap dispenser
2. Emergency stop
3. USB Port
4. Drain
5. Electric connection to liquid soap pumps
6. Electrical connection
7. Main switch
8. Auxiliar water inlet
9. Hot water inlet
10. Equipotential connection
11. Cold water inlet
12. Blur output / water overload
13. Liquid soap connection
14. Steam connection
15. Ethernet port

		A	B	C	D	E	F	G	H	I	J	K	L	M	N	O	P	Q	R	S	T	U	V	W	X	Y	CGY	CGZ
DLS-18	mm	788	935	1.307	348	460	143	552	1.035	1.203	1.038	1.222	1.107	61	74	101	385	445	706	544	245	724	676	1.202	485	1.202	479	546
	inch	31,02	36,81	51,46	13,70	18,11	5,63	21,73	40,75	47,36	40,87	48,11	43,58	2,40	2,91	3,98	15,16	17,52	27,80	21,42	9,65	28,50	26,61	47,32	19,09	47,32	18,86	21,50