

TOUCH II

7" touch screen easy to use and fully programmable.
 Screen on both sides of the machine.
 Connection USB. Free software online for programming, telemetry, data analysis, etc.
 37 languages.
 8 dosing signals as standard.

OUTSTANDING FEATURES

Automatic positioning of drum with motor brake.
 3 water inlets.
 Wet Cleaning, telemetry standard.
 G FACTOR 375
 Heating: electric, steam and dual heating model (electric+steam).

EFFICIENCY

Intelligent consumption: automatic adjustment of water and soap consumptions (standard).
 Optimal loading: manual indication of weight.
 Water Recovery tanks ready: **ECOTANK XL**.
 Low water consumption.
 High G FACTOR: reduced residual moisture > reduced drying time.

CONNECTIVITY

IoT - **DOMUSCONNECT** standard
 Remote technical service.
 Laundry management.

ERGONOMICS

Huge door opening making loading/unloading easier.
 User-friendly drum opening by push button.
 Loading height: door base 800 mm.
 Pullman drum: load optimisation (in option), (mod. DHB-27 up to DHB-50).

MAINTENANCE

Electric components on the left side, mechanical components on the right side and connections on the top (protected from water and detergents).
 Central drain as standard.
 Technical menu: statistics, alarms, autotest, data recovery for technicians and maintenance.

OTHERS

2 opposed doors. Pass-through barrier washer.
 Ready to be connected to dosing pumps.
 Grey skinplate outer casing.
 Drum and vat in stainless steel AISI 304.
 Frequency inverter to control imbalance.
 CE approved product.



OPTIONS

- License IoT - DOMUSCONNECT
- Ready for ECOTANK XL conn. 1" for barriers DHB-50
- Model with a single door DHB-50
- Pullman drum for DHB-50
- Weighing sensor system on feet for DHB-27 to DHB-50. Includes kit with 6 extra dosing signals.
- 6 extra dosing signals card
- 2nd drain valve
- Titration valve
- Inner door open sensor DHB-27/35/50
- Side drain valve
- Low steam pressure
- 4 compartments detergent box
- UPS option (in case of power failure)
- End of cycle light alarm
- Plinth to align the doorbase at 850mm DHB-50
- Stainless steel AISI 304 outer casing for DHB-50
- Maritime wooden packing for DHB-50
- 230V III 50/60Hz DHB-50
- Stainless steel frame for DHB-50
- 440V III 60Hz DHB-27 to DHB-70
- Steel frame DHB-50 equipped with loading base

DRUM	UNIT.	DHB-50 TOUCH II	
Load capacity 1:9	Kg	54,3	
	lb	119,8	
Load capacity 1:10	Kg	49	
	lb	108	
Volume	l	489	
	ft ³	17,27	
Diameter	mm	800	
	inch	31,5	
Depth	mm	974	
	inch	38,3	
Drum compartments	Nº	1	
GENERAL DETAILS			
Washing speed	rpm	45	
Spining speed	rpm	920	
G Factor	-	375	
TOUCH II Control	-	7"	
Double screen	-	STD	
Motor break	-	STD	
Double drainage	-	OPT	
DOOR			
Drum opening dimensions	mm	640 x 515	
	inch	25.2 x 20.3	
Vat opening dimensions	mm	700 x 650	
	inch	27.5 x 25.6	
Height door bottom	mm	800	
	inch	31,5	
POWER			
Motor	kW	5,5	
Electric heating (elec. mod)	kW	36	
Total electric power (elec. mod)	kW	41,5	
	kW	5,5	
Total electric power (steam mod)	kW	5,5	
CONNECTIONS		E/DUAL	S
Tension 230V I + N + T 50/60Hz	Nº x mm ² /A	-	-
Tension 230V III + T 50/60Hz	Nº x mm ² /A	4 x 25 / 125A	4 x 2,5 / 16A
Tension 400V III + N + T 50/60Hz	Nº x mm ² /A	5 x 16 / 63A	5 x 2,5 / 10A
Water inlets number	-	3	
Water inlet	mm	26/34	
	inch	1"	
Water pressure	bar	3 - 5	
	psi	43 - 72	
Steam inlet (steam mod)	inch	3/4"	
Steam pressure	bar	4-8	
	psi	58-116	
Drain number	-	1	
Drain evacuation capacity	l/min	200	
	cfm	5,65	
Drain	mm	80	
	inch	3"	
OVERALL DIMENSIONS			
Net / Gross width	mm	1.717 (1.869) / 1.903	
	inch	67,6 (73,6) / 74,9	
Net / Gross depth	mm	1.195 / 1.300	
	inch	47 / 51,2	
Net / Gross height	mm	1.615 / 1.720	
	inch	63,6 / 67,7	

Net / Gross weight	kg	1.063 / 1.085
	lb	2.344 / 2.392
Volume	m ³	4,26
	ft ³	150,3

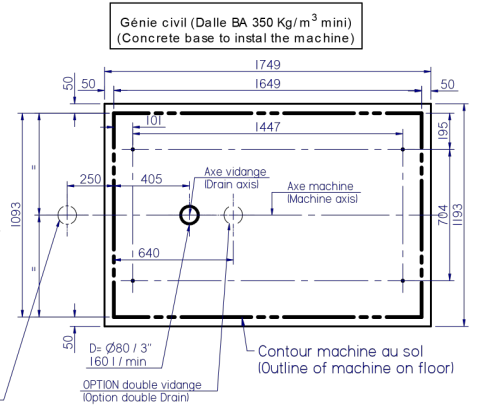
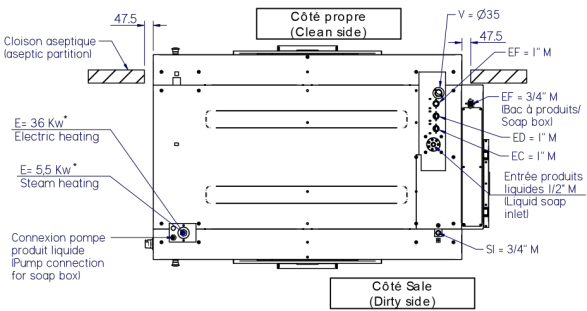
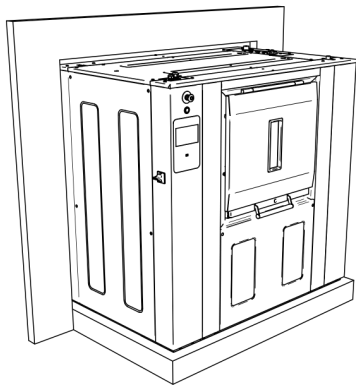
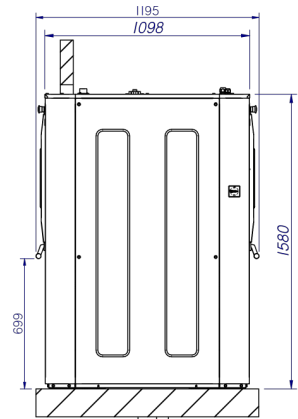
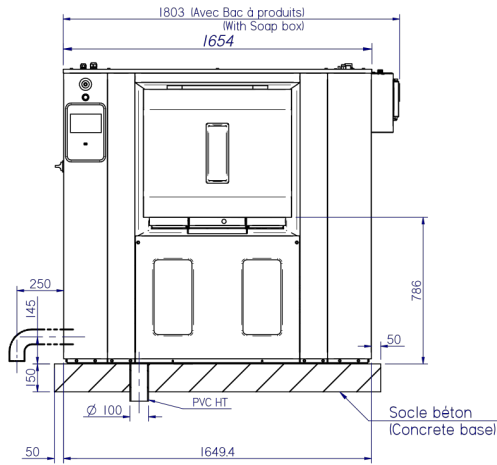
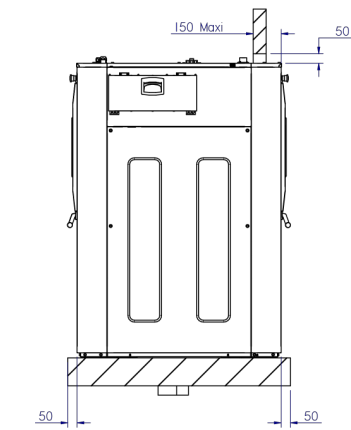

E = Electricity

(* refer to "user & installation manuel " §2.2.6 - p10 (pour détails / for details)

EC/ED/EF = Eau Chaude / Douce / Froide
hot water / soft / cold

1" M - 3/5 Bars - 130 l/min MAX

3/4" M - 3/5 Bars - 100l/min MAX

SI = Entrée vapeur / Steam Inlet

6 Bars / 240 Kg/h - Max 10 Bars

V= Event / Vent

D = Vidange / Drain

Nota : inlet)

- Pour les arrivées d'eau, vapeur et électricité, les machines devront être installées selon les normes en vigueur.(This machine must be installed in compliance with all local regulations)

- Le chassis doit impérativement porter sur toute sa longueur et sur un sol parfaitement plan et de niveau. (The frame must be installed on a perfectly level floor)

- Il est impératif de fixer la machine au sol par les orifices prévus à cet effet. (This machine must be fixed on the floor by threaded rods)