

TOUCH II

- TOUCH II: Easy-to-use microprocessor, fully programmable with a 7" touchscreen.
- USB port: configure, update, and analyse machines without internet connection.
- On-screen videos: add your logo, video advertisements or instructions for use (useful for self-service).
- Multilingual interface.
- 8 standard dosing signals and 6 extra as an option.

G FACTOR

G FACTOR 200: 11 - 45 kg.
G FACTOR 150: 60 - 80 kg.

EFFICIENCY

Intelligent consumption: automatic adjustment of water and soap consumptions (standard).
Optimal loading: manual indication of weight.
Low water consumption.

VERSATILITY

Make to order: customisation.
OPL < > Self-service.
Electric < > Hot water.
Wet Cleaning features.

CONNECTIVITY

IoT - **DOMUSCONNECT** standard.
Remote technical service.
Management of laundries: self-service & OPL.
Remote payment.

ERGONOMICS

Easy opening/closing system for door lock.
Biggest door diameters:
• Ø 373 (11, 14 kg)
• Ø 460 (18, 22 y 28 kg)
• Ø 560 (35, 45, 60, 80 kg)

MAINTENANCE

Hinged control panel: easy and ergonomic access.
Technical menu: statistics for technicians.
Equivalent parts for all models: electronic parts, contactors.

OTHERS

Hard mounted washers.
Anchoring to floor with anchoring base.
Panels in skinplate.
Drum and vat in stainless steel AISI 304.
3 water inlets.
CB and WRAS approved product. Option ETL.
REG4 standard certified by KIWA.



OPTIONS

- License IoT - DOMUSCONNECT
- Ready for ECOTANK XL conn. 3/4" for washers DLS/DHS-11/14/18/22/28
- DOSING PUMP KIT DQ-2
- EXTRA DOSING PUMP DB-1
- SLUICE - Drum with 8 mm holes for DLS-11
- Kit watermark Australia
- Anchoring base for DLS-11
- External double drain 3" (recom. for DLS-11/14)
- Normally closed valve DLS-11
- Water recycle DLS-11
- 6 extra dosing signals card for DLS-11 to DLS-45C
- Silicon gasket DLS-11/14
- Reversible door: reverse door opening
- Tropicalized model: protected board for DHS-11 - 45C / DLS-11 - 80C
- Kit to transform an E or HW for DLS-11/14/18/22 to steam
- Stainless steel AISI 304 outer casing for DLS-11
- Stainless steel AISI 304 top and front panel for DLS-11
- 440V 3~ (No N) 50/60 Hz DLS-11 (marine)
- KIT 110/230V 1,2KV DLS-11/14/18
- Kit watermark Australia
- Several payment systems for self-service
- Auto unlock kit for the door (in case of power failure) DLS-DHS

TECHNICAL DATA	UNIT.	DLS-11 TOUCH II	
DRUM			
Load capacity 1:9 / 1:10	Kg	11/10	
Volume	l	100	
	gal	26,4	
Diameter	mm	620	
	inch	24,1	
Depth	mm	330	
	inch	12,99	
GENERAL DATA			
Washing speed / Spin speed	r.p.m.	53/759	
G factor	-	200	
Maximum transmitted force	KN	2,0 ±3	
Dynamic force frequency	Hz	8,93	
Sound level	dB	< 70	
Self-service version	-	YES	
Double drain	-	NO	
Weighing system / Tilting system	-	NO	
SLUICE option	-	YES	
DOOR			
Door centre height / Door base height	mm	570/310	
	inch	22,4"/12,2"	
Diameter	mm	373	
	inch	14,6"	
POWER			
Motor	kW	1,1	
Electric heating (electric model)	kW	6	
Maximum electric power	kW	6,25	
Max. power steam & hot water model	kW	1,1	
CONNECTIONS		E	HW/S
Voltage 110V - 1 + N + E	Nº x mm ² / A	-	-
	Nº x AWG / A	-	-
Voltage 230V - 1 + N + E	Nº x mm ² / A	3x6 / 40A	3x1,5/ 16A
	Nº x AWG / A	3x9 / 35A	3x14 / 15A
Voltage 230V - 3 + E	Nº x mm ² / A	4x2,5 / 20A	-
	Nº x AWG / A	4x13 / 20A	-
Voltage 400V - 3 + N + E	Nº x mm ² / A	5x1,5 / 16A	-
	Nº x AWG / A	5x15 / 15A	-
Steam inlet (steam model)	inch	1/2"	
Max. steam consumption (steam model)	Kg/h	7	
Water inlet	inch	3/4"	
Water pressure	Kgs/cm ²	2-4	
Max. water consumption*	Lit/h	61,5*	
	GPH	16,2*	
Drain	mm/inch	3"	
Drain capacity	Lit/min	200	
	GPM	52,8	
DIMENSIONS / PACKED DIMENSIONS			
Net width / Gross width	mm	719 / 782	
	inch	28,3"/30,78"	
Net depth / Gross depth	mm	755 / 890	
	inch	29,7"/35"	
Net height / Gross height	mm	1.165 / 1.400	
	inch	45,8"/55,1"	
Net weight / Gross weight	kg	198 / 231,6	
	lb	436,5/510,59	

Packing volume	m3	0,97
	ft3	34,2

Programme no.20, 75% load

**Programme no.2, 100% load

*** 400V version = 48kW / 230V = 36kW

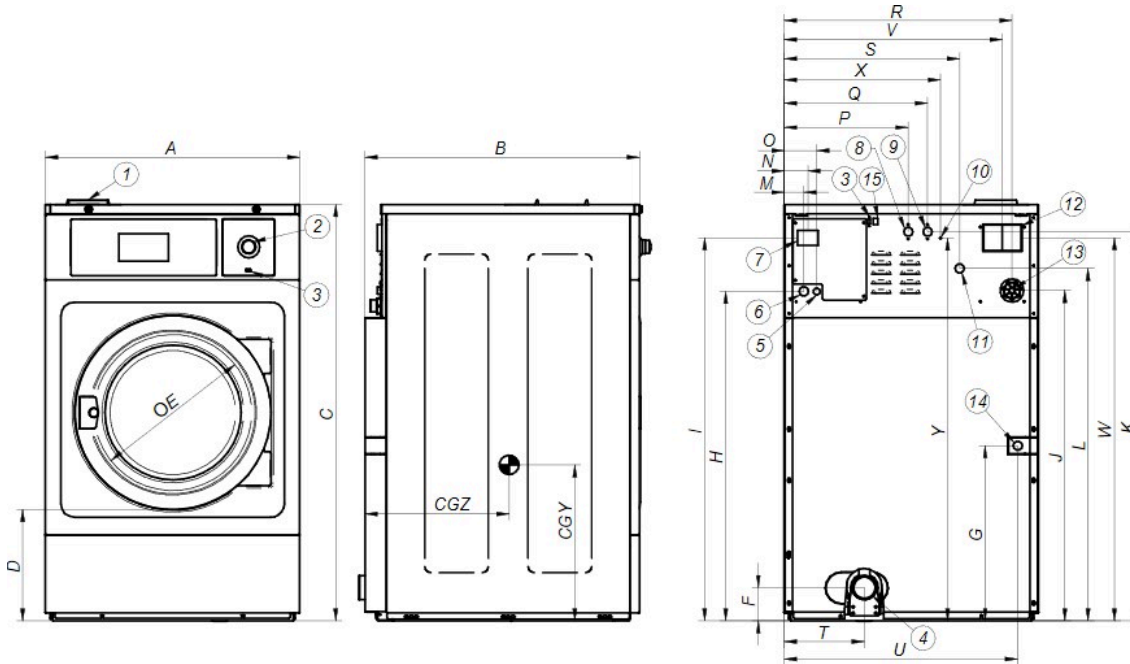

1. Soap dispenser
2. Emergency stop
3. USB Port
4. Drain
5. Electric connection to liquid soap pumps
6. Electrical connection
7. Main switch
8. Auxiliar water inlet
9. Hot water inlet
10. Equipotential connection
11. Cold water inlet
12. Blur output / water overload
13. Liquid soap connection
14. Steam connection
15. Ethernet port

	A	B	C	D	E	F	G	H	I	J	K	L	M	N	O	P	Q	R	S	T	U	V	W	X	Y	CGY	CGZ	
DLS-11	mm	719	755	1.165	310	373	148	440	886	1.054	889	1.073	958	61	74	101	316	376	637	475	211	654	607	1.053	416	1.053	383	511
	inch	28,31	29,72	45,87	12,20	14,69	5,83	17,32	34,88	41,50	35,00	42,24	37,72	2,40	2,91	3,98	12,44	14,80	25,08	18,70	8,31	25,75	23,90	41,46	16,38	41,46	15,08	20,12