

 **FEATURES**

Flatwork ironer with roll sizes: 2.600 and 3.300mm wide and 600, 800 and 1.000mm diameter.

Panels in painted steel.

One or two working lanes: one lane for bedsheets and two lanes for tablecloths and small pieces.

Lengthfold with 1 or 2 folds in two independent lanes.

Folding system by photocells and compressed air.

Frequency control.

Feeding and ironing belts are NOMEX.

Touch-screen control: programs can be created with speed control (between 3 and 18 mts/min), temperature and folding parameters.

Automatic stop after cooling down (at 80°C).

Big output capacity, depending on the residual moisture of the linen, up to 290kg/hour straight from the high spin washer extractor.

Electric, gas or steam heating.

Powerful exhaust system.

Gas models with radiant burner (increase of 25% more production, available in diameter 800 models and standard in diameter 1.000mm models).

**OPTIONS**

- Vacuum feeding belts to help the linen feeding
- Automatic 1 lane clamp feeder without vacuum feeding belts
- Rear exit + bypass
- Crossfolder CPL-CROSS 260 + stacker for SP
- Crossfolder CPL-CROSS 330 + stacker for SP
- Motorized rear exit - height 860 mm. includes rear exit
- Small pieces back collector: 2 lanes for SP
- Small pieces back collector: 4 lanes for SP
- By-pass
- Double air pressure in length folds for thicker linen
- Linen reject system (dirty or torn)
- Different voltage from 400V III +N 50Hz
- Maritime packing for SP

GENERAL DATA	UNIT.	SP600-2600
Theoretical production* elec/steam/atm. Gas heating	Kg/h	125
Theoretical production* radiant gas burner	Kg/h	-
Ø Roll	mm	600
Working width	mm	2.600
Height floor-feeding	mm	1.050
Working speed	mt/min	3-10
Control type	-	Digital
Nº of programs	Nº	20
FOLDING		
1 lane - lengthfold	Nº	1-2
2 lanes - lengthfold	Nº	1-2
POWER		
Electric heating	kW	54
Max. electric power electric heating	kW	55,9
Gas heating (natural / LPG)	kW	63,30 / 67,40
Max. electric power gas heating	kW	1,9
Steam heating	kW	55
Max. electric power steam heating	kW	1,9
CONNECTIONS		
Ø Gas inlet	BSP	1"
Ø Steam inlet (12 bar max.)	BSP	1"
Ø Condensed (steam models)	BSP	1/2"
Ø Air inlet	BSP	12
DIMENSIONS / PACKAGING DIMENSIONS		
Net width / gross width	mm	3.670 / 3.830
Net depth / gross depth	mm	1.440 / 1.620
Net height / gross height	mm	2.030 / 1.960
Net weight / gross weight	Kg	2.050 / 2.300
Volume	m ³	10,73 / 12,16
OTHERS		
No. Fume outlet	Nº	2
Ø Fume outlet	mm	120
Extraction rate	m ³ /h	2 x 1.000
Compressed air consumption (6,5 bar)	mm	7.000
Sound Level	dB	70

* 50% residual moisture, 140gr/m² of cotton, 100% roll utilization

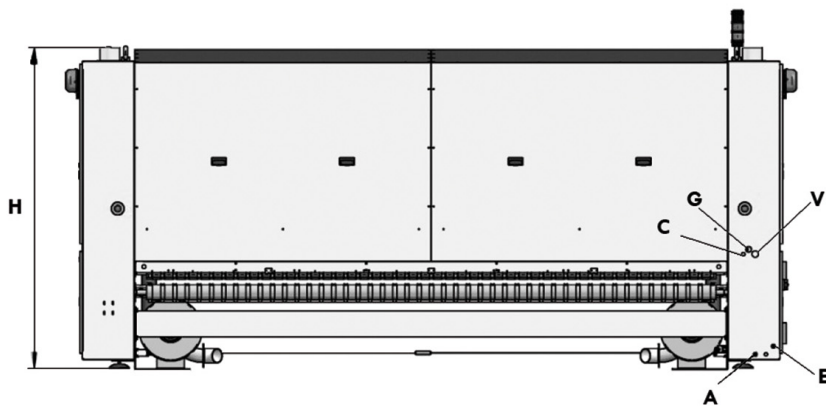

- A. Compressed air inlet
- C. Condensation discharge (steam models)
- E. Electrical connection
- F. Fumes extraction
- G. Gas inlet
- V. Steam inlet

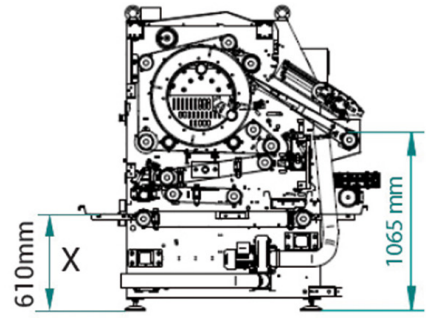
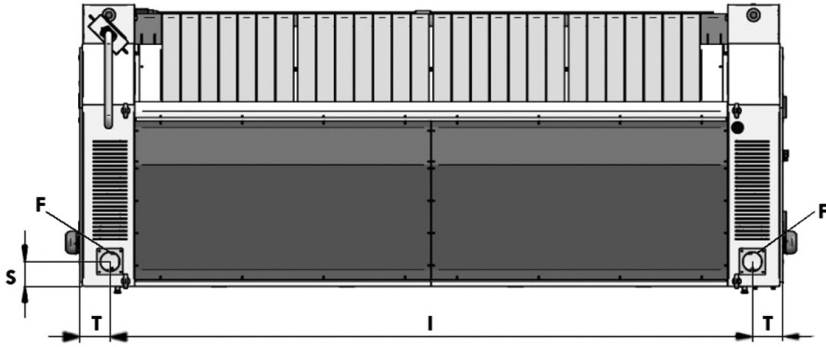

	H	I	T	S	A	C	E	F	G	V
SP600-2600	1.800	3.242	186	152	Ø12	1/2"	5x2,5	Ø120	1"	1-1/4"
SP600-3300	1.800	3.942	186	152	Ø12	1/2"	5x2,5	Ø120	1"	1-1/4"