

### TOUCH II

- **TOUCH II:** easy-to-use microprocessor, fully programmable with 7" touchscreen.
- Multilingual interface.
- Unlimited programmes: in addition to presets, create as many as your business needs.
- USB port: configure, update, and analyse machines without an internet connection.

### EFFICIENCY

- **EFFICIENT IRON:** automatically adjusts ironing speed based on residual moisture, saving energy.
- **OPTIMAL FEEDING:** automatic ironing speed adjustment (optional).
- Excellent heat transfer thanks to the roller's material and thickness.
- Auto stop at 80 °C: extends lifespan of ironing belts.
- Gas circuit at the bottom, reducing energy consumption.
- Accurate temperature control via microprocessor: low energy use.
- Models with radiant gas burner: up to 25% more output - saving time and energy.

### ROBUSTNESS

- Roller with inverter.
- Panels in skinplate.
- Ironing belts in Nomex: resistant to high temperatures.
- Nickel-plated cylinder - corrosion-resistant and longer lasting (optional).

### ERGONOMICS

- Acoustic comfort: max 65 dB.
- Easy to clean, more hygienic.
- Optimal feeding height: 1,120 mm.
- LED indicator 3 ironing zones for easier operation (optional).

### MAINTENANCE

- Easy access to all components on both sides of the machine.
- Connections: electrical and flue gas.
- Comprehensive technical menu: statistics, self-test, data retrieval for technicians and maintenance.
- Remote communication: rapid intervention.

### VERSATILITY

- Radiant gas model: flexibility for higher output and better adaptation to high-ceiling spaces.
- Key options:
  - **SRE:** Standard rear outlet without folder (new).
  - **LF:** Front outlet with integrated folder.
  - **LFRE:** Front and rear outlet with integrated folder.
  - **CPL-CROSS:** External transverse folder.

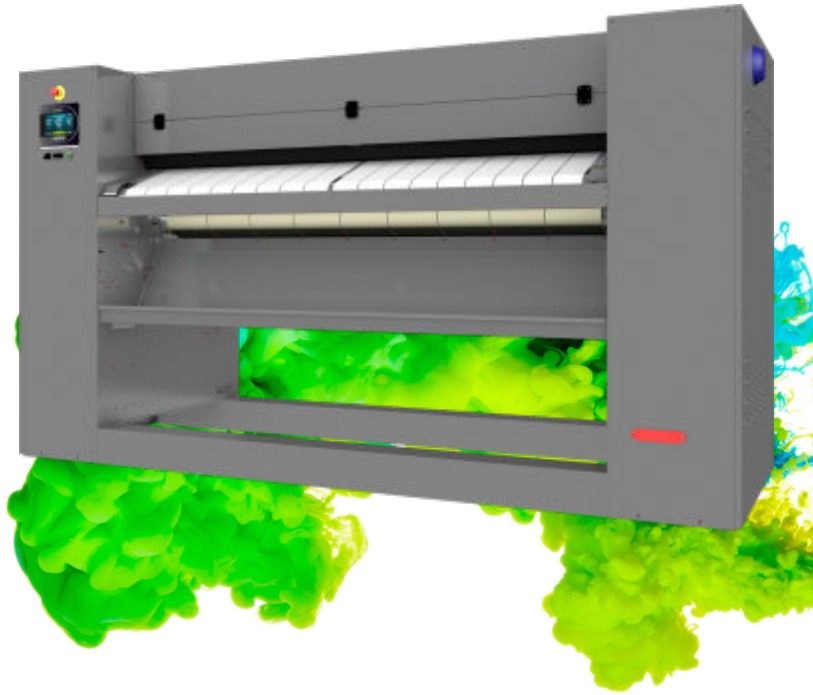

### OPTIONS

- Feeding tray CF-2050
- Leveling feet kit
- 3-zone LED ironing indicator
- **EFFICIENT IRON :** humidity control
- **OPTIMAL FEEDING -** high production HPS system
- Nickel Plated roll CF-2050 E/G (not in Steam)
- Gas LPG option (Propan) for radiant gas model
- Gas NG option (Natural Gas) for radiant gas model
- Built-in lengthfolder CF-2050 (front exit)
- Built-in lengthfolder + rear and front exit CF-2050
- Rear exit without folder CF-2050
- Cross folder CPL-CROSS CF-2050
- Antistatic belts for CF-2050 without folder
- No drop tray (laundry recovery) CF-2050
- Antistatic ironing belts + bar CF-2050 for folder
- Maritime wooden packing CF-2050
- 230V 3~ 50/60Hz CF-2050 E
- 230V 3~ 60Hz CF-2050 G
- 440V 3~ 50/60Hz CF-2050 E (marine)
- 120V 1~ + N 60Hz CF-2050 G (Gas US)

GENERAL DETAILS	UNIT.	CF-2050 TOUCH II	
Theoretical output Electric, steam and atmo. gas heating* standard mod. front or rear exit	Kg/h	68	
	lb/h	150	
Theoretical output Electric, steam and atmo. gas heating* mod. Folder front exit	Kg/h	48	
	lb/h	105	
Theoretical output Electric, steam and atmo. Gas heating* mod. Folder front and rear exit	Kg/h	44	
	lb/h	97	
Theoretical production Radiant gas heating* mod standard front or rear exit	Kg/h	82	
	lb/l	181	
Theoretical production Radiant gas heating* mod folder front exit	Kg/h	57	
	lb/l	127	
Theoretical production Radiant gas heating* mod folder front and rear exit	Kg/h	53	
	lb/l	118	
Roll Ø	mm	500	
	inch	19,69	
Working width	mm	2.000	
	inch	78,74	
Height floor-feeding belts	mm	1.170	
	inch	46,06	
Working speed standard mod.	m/min	0,5 - 8	
	ft/min	1,6 - 26	
Working speed mod. with folder	m/min	2 - 8	
	ft/min	6,5 - 26	
Electronic control	-	TOUCH II	
No. Programs	-	5	
Lenght folder	-	OPT.	
Rear exit	-	OPT.	
Large surface contact with linen	-	305°	
POWER			
Roll motor power	Kw	0,41	
Fan motor power	Kw	0,25	
Electric mod.: heating power	Kw	31,5	
Electric mod: Total electric power	Kw	32,16	
Gas mod.: heating power	Kw	40	
Gas mod.: total electric power	Kw	0,66	
Steam mod.: heating power	Kw	50	
Steam mod.: total electric power	Kw	0,66	
Steam consumption	Kg/h	50	
Additional electric power standard mod. Rear exit	Kw	0,28	
Additional electric power mod with folder front exit	Kw	0,56	
Additional electric power mod with folder front and rear exit	Kw	0,66	
CONNECTIONS		E	G/S
Tension 230V - I + N + T	Nº x mm² / A	N/A	3 x 2,5 / 10A
	nº x AWG/A	N/A	3 x 13 / 10A
Tension 230V - III + T	Nº x mm² / A	4 x 25 / 100A	4 x 2,5 / 10A
	nº x AWG/A	4 x 3 / 100A	4 x 13 / 10A
Tension 400V - III + N + T	Nº x mm² / A	5 x 16 / 63A	5 x 2,5 / 10A
	nº x AWG/A	5 x 5 / 63A	5 x 13 / 10A
Ø Gas inlet	BSP	1"	
Ø Steam inlet	BSP	3/4"	
Ø Condensed (Steam models)	BSP	1/2"	
OVERALL DIMENSIONS / PACKING DIMENSIONS			
Net width / Gross width	mm	3110 / 3290	
	inch	122,4 / 129,5	
Net depth (with rear exit open) / gross depth	mm	1175 (1507) / 1360	
	inch	46,3 (59,3) / 53,5	
Net height / gross height	mm	1780 / 1940	
	inch	70,1 / 76,4	

Net weight / gross weight standard mod.	kg	1130 / 1190
	lbs	2491 / 2624
Net weight / gross weight standard mod. with rear exit	kg	1160 / 1220
	lbs	2557 / 2690
Net weight / gross weight mod. Folder front exit	kg	1190 / 1250
	lbs	2624 / 2756
Net weight / gross weight mod. Folder front and rear exit	kg	1240 / 1300
	lbs	2734 / 2866
Net volume (with rear exit) / Gross volume	m <sup>3</sup>	6,50 (7,99) / 8,68
	f <sup>3</sup>	230 (282) / 307
<b>OTHERS</b>		
No. Fume outlet	Nº	1
Ø Fume outlet	mm	153
	inch	6,0
Air Flow	m <sup>3</sup> /h	600
	cfm	353
Sound level	dB	65
Evaporation power standard mod.	l/h	37
	USgallon/h	9,7
Evaporation power mod. Folder front exit	l/h	26
	USgallon/h	6,8
Evaporation power mod. Folder front and rear exit	l/h	24
	USgallon/h	6,3

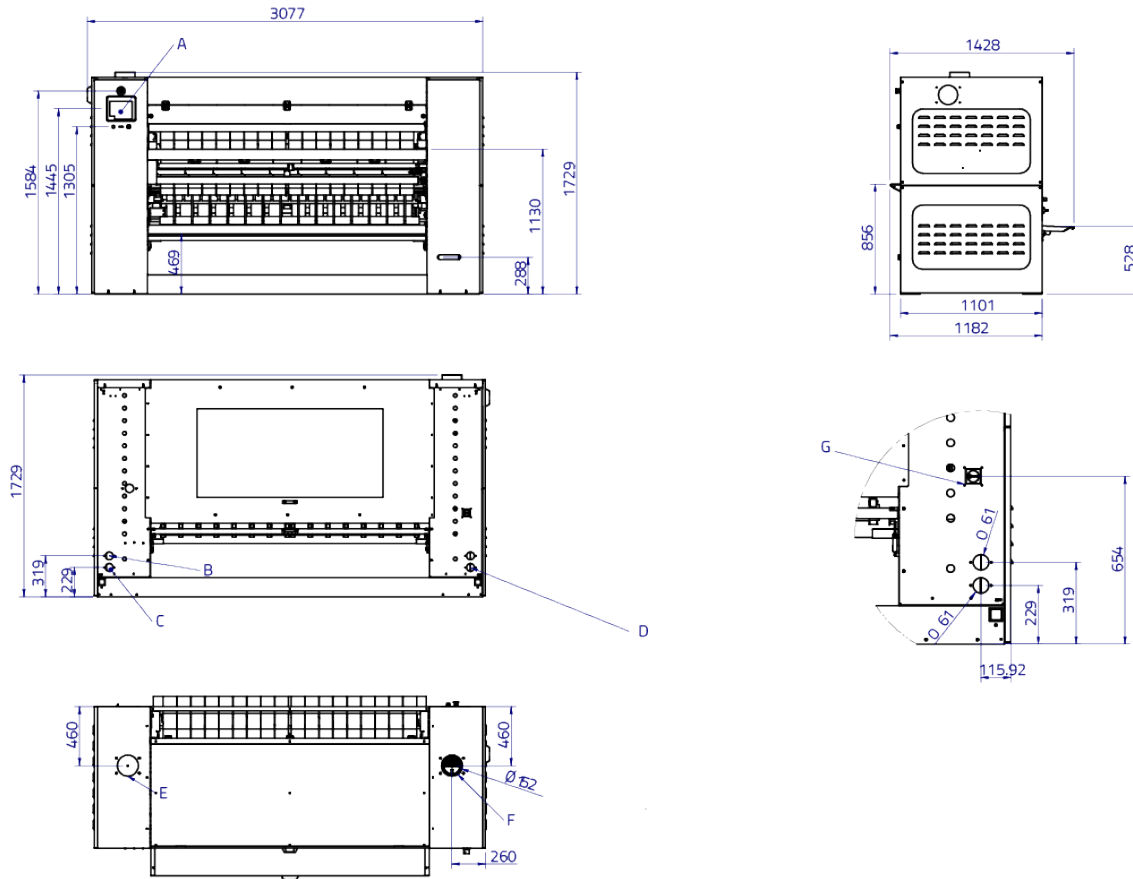

- A. Touch-screen control tablet
- B. Steam outlet ø1/2" male
- C. Gas inlet ø22 or steam ø3/4" male
- D. Electrical inlet
- E. NO EXHAUST
- F. (Exhaust) ø152 external
- G. Isolator