



ELECTRONIC PROGRAMMER

Simple and user friendly with an auto mode: automatic management of the ironing speed according to the selected temperature.
Digital speed and temperature display.



EFFICIENCY

Good heat conduction thanks to the roll material and thickness: greater control of energy expenditure.
Automatic shutdown at 80°C (adjustable parameter).
Fumes circulation circuit from the bottom reducing energy consumption.



ROBUSTNESS

Roll driving by inverter: smooth operation preventing the wear of belts and mechanical elements.
Nomex quality feeding and ironing belts: high temperatures resistant.
Skinplate and stainless steel panels: long lasting.
Coiled felt for greater lifespan.



ERGONOMICS

Acoustic comfort: <65 dba.
Appropriate height of feeding: 990 mm.
Compact design: fits in many spaces.
Electronic control with Auto mode: easy to use, optimized ironing speed.



MAINTENANCE

Easy access to all components on both sides of the machine.
Basic connections: electrical connection and air extraction.



OTHERS

Dries and irons flat linen from a high spin washer extractor in a single operation.
Front feeding and return.
Built-in COOL DOWN system.
Polished steel roll Ø 325 mm.
Roll length: 1.400mm, 1.600mm and 2.000mm.
Electric or atmospheric gas heating.
CE standard



OPTIONS

- EFFICIENT IRON: humidity control Ø 325
- Nickel plated roll CM-1432
- Maritime wooden packing for CM-1432
- 230V I N 50Hz gas CM-1432
- 230V I N 60Hz gas CM-1432
- 230V III 50/60Hz electric CM-1432
- 440V III 50/60Hz electric CM-1432 (maritime)

GENERAL DETAILS	UNIT.	CM-1432 M	
Theoretical production*	Kg/h	18	
	Lb/h	40	
Atmo. gas theoretical production*	Kg/h	22	
	Lb/h	49	
Evaporation power	l/h	8,1	
	USgallon/h	2,1	
Roll Ø	mm	325	
	inch	12,80	
Working width	mm	1.400	
	Inch	55,1	
Height floor-feeding belts	mm	990	
	Inch	39	
Working speed	mt/min	1,5 - 10	
	ft/min	4,9 - 32	
Electronic control	-	YES	
No. Programs (BM Modes)	Nº	2	
POWER			
Heating power	kW	12	
Total electric power	kW	12,37	
Gas heating	kW	14	
Total electric power (gas mod.)	kW	0,37	
Roll motor	kW	0,28	
Fan motor	kW	0,12	
CONNECTIONS		E	G
Tension 230V I + N + T	nº x mm²/A	N/A	3 x 2,5 / 6A
	nº x AWG/A	N/A	3 x 13 / 6A
Tension 230V III + T	nº x mm²/A	4 x 10 / 40A	4 x 2,5 / 6A
	nº x AWG/A	4 x 7 / 40A	3 x 13 / 6A
Tension 400V III + N + T	nº x mm²/A	5 x 6 / 20A	5 x 2,5 / 6A
	nº x AWG/A	5 x 9 / 20A	5 x 13 / 6A
Ø Gas inlet	BSP	1/2"	
DIMENSIONS / PACKING DIMENSIONS			
Net / gross width	mm	1.952 / 2.340	
	inch	76,9 / 92,1	
Net / gross depth	mm	686 / 770	
	inch	27 / 30,3	
Net / gross height	mm	1.112 / 1.400	
	inch	43,8 / 55,1	
Net / gross weight	Kg	330 / 365	
	lb	728 / 805	
Volume	m³	1,49 / 2,52	
	ft³	52,59 / 89,08	
OTHERS			
No fume outlet	Nº	1	
Ø Extraction	mm	98	
	inch	3,86	
Airflow	m³/h	500	
	cfm	294	
Sound level	dB	60	

* 45% moisture

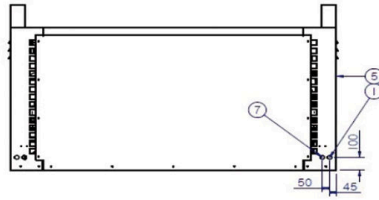
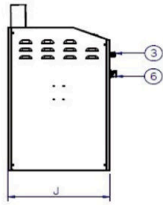
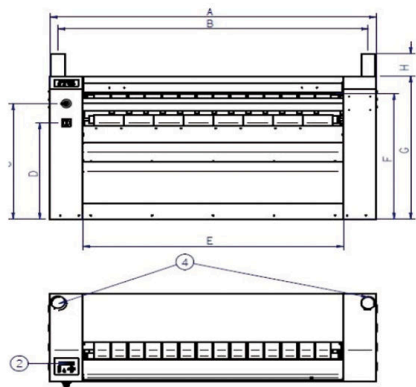

1. Electrical connection
2. Vapour extraction
3. Main switch
4. Emergency stop
5. Crank handle
6. Electronic control

	A	B	C	D	E	F	G	H	I	J
CM-1432 M	1.952	1.846	900	750	1.510	980	1.112	140	746	686
CM-1632 M	2.202	2.096	900	750	1.760	980	1.112	140	746	686
CM-2032 M	2.552	2.446	900	750	2.110	980	1.112	140	746	686