

ELECTRONIC PROGRAMMER

PR-1025, PR-1225, PR-1425, PR-2025

Digital screen: precise control of temperature.
Preset ironing speeds, not adjustable.

PR-1425, PR-2025 ECO-ENERGY

Simple and user friendly with an **automatic mode**: automatic management of ironing speed according to the selected temperature.
Digital speed and temperature display.

EFFICIENCY

Acoustic comfort: 65 dB max.
Minimum space requirement: space saving, suitable for small spaces.
Ideal for processing small quantity of flat linen in facilities like restaurants, guest rooms, hostels.

ROBUSTNESS

Nomex quality coating: resistant to high temperatures (option, standard on ECO-ENERGY).
Panels in grey Skinplate and stainless steel.
Wooden feeding board.
Industrial components, more durable.

OUTSTANDING FEATURES

Large roll contact area with the linen.
Roll lifting control by pedal or automatic roll lifting control by foot cell detection.
Two available models:

- **Standard**: roll with cotton polyester coating.
- **Nomex**: roll with Nomex coating.

ECO-ENERGY Models:

Large roll contact area with the linen.
Mode of operation identical to a flatwork ironer: no roll lifting, more ergonomic.
Models equipped with Nomex belts, suction and variable speed inverter, more productivity.
Adjustable speed and temperature.

MAINTENANCE

Easy installation: requires only an electrical connection.
Easy access on both sides for maintenance.
Quick and easy dismantling of bearings.

OTHERS

Front feeding and return.
Roll Ø 250 mm.
Working widths: 1.000, 1.200, 1.400 and 2.000 mm.
Electric heating.
CE certification.

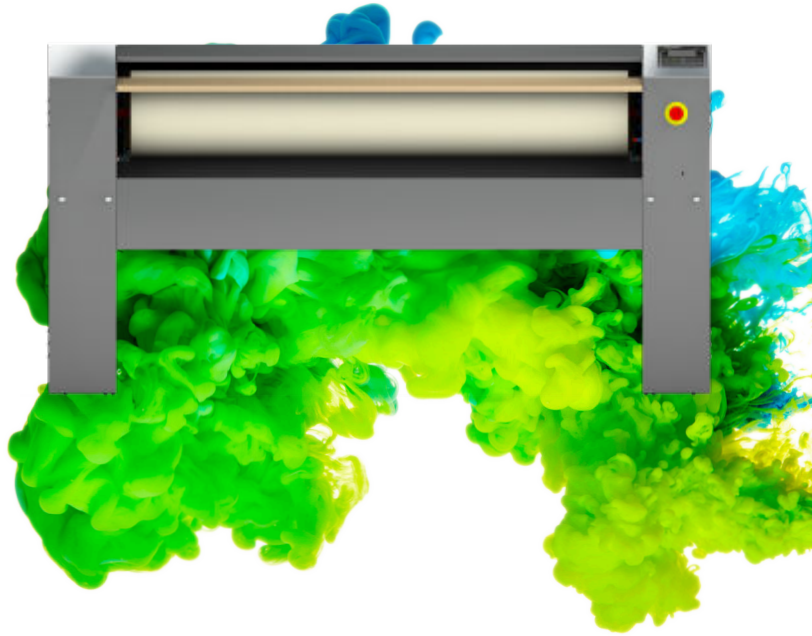

OPTIONS

- 230V I + N 50Hz (except PR-2025 ECO-ENERGY)
- 400V +N+T 60Hz
- 440V III No N 60Hz (maritime)

GENERAL DETAILS	UNIT.	PR-2025 NOMEX ECO-ENERGY
Theoretical production: 20-25 humidity	Kg/h	50
	Lb/h	110,23
Roll Ø	mm	250
	inch	9,84
Working width	mm	2.000
	inch	78,74
Working speed	m/min	1.5-6
	ft/mn	4,9 - 19,6
Electronic control	-	YES
Chest motion	-	NO
POWER		
Heating power	Kw	12
Roll motor power	Kw	0.18
Fan motor power	Kw	0.12
Total electric power	Kw	12.3
CONNEXIONS		
Tension 230 V I + N + T	n° x mm²/A	-
	n° x AWG/A	-
Tension 230 V III + T	n° x mm²/A	4 x 10 / 40A
	n° x AWG/A	4 x 7 / 40A
Tension 400 V III + N + T	n° x mm²/A	5 x 4 / 20A
	n° x AWG/A	5 x 11 / 20A
DIMENSIONS		
Net / gross width	mm	2.462 / 2.490
	inch	96,93 / 98,03
Net / gross depth	mm	484 / 540
	inch	19,06 / 21,26
Net / gross height	mm	985 / 1.130
	inch	38,78 / 44,49
Net / gross weight	Kg	164 / 184
	Lb	361,56 / 405,65
Net / gross volume	m³	1,17 / 1,51
	ft³	41,32 / 53,33
OTHERS		
No. Fume outlet	Nº	1
Ø Fume outlet	mm	80
	inch	3,15
Air flow	m³/h	500
	cfm	294,29
Noise Level	dB	60

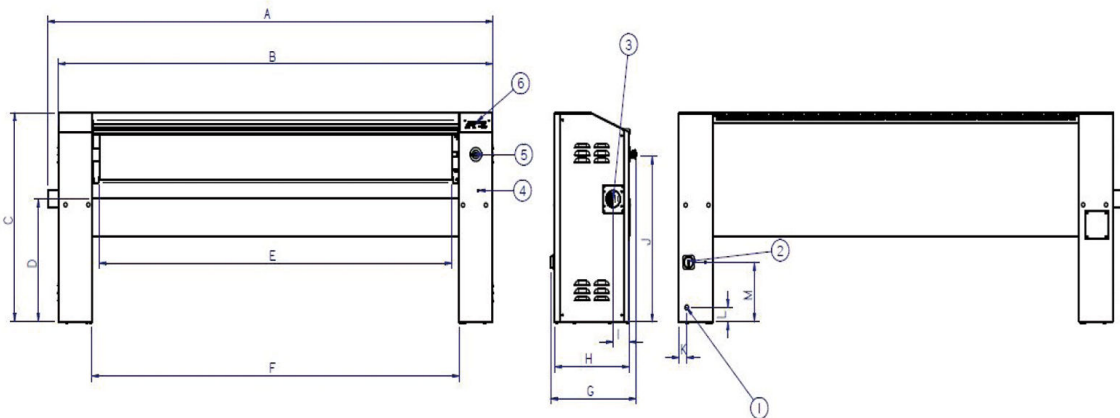

1. Electrical connection
2. Main switch
3. Vapour outlet
4. Crank handle
5. Emergency stop
6. BM control panel

	A	B	C	D	E	F	G	H	I	J	K	L	M
PR-1425 NOMEX ECO-ENERGY	1.922	1.862	985	610	1.400	1.480	484	423	91	791	45	75	287
PR-2025 NOMEX ECO-ENERGY	2.522	2.462	985	610	2.000	2.080	484	423	91	791	45	75	287