

## TOUCH II

- TOUCH II: Easy-to-use microprocessor, fully programmable with a 7" touchscreen.
- USB port: configure, update, and analyse machines without internet connection.
- On-screen videos: add your logo, video advertisements or instructions for use (useful for self-service).
- Multilingual interface.
- 8 standard dosing signals and 6 extra as an option.

## G FACTOR

High G-factor of 500 (11-18 kg), 450 (22-80 kg), and 350 (100-120 C).  
Reduces residual moisture

## EFFICIENCY

Optimal loading: manual indication of weight.  
Intelligent consumption: automatic adjustment of water and soap consumptions (standard).  
Water Recovery tanks ready: **ECOTANK** and **ECOTANK XL**.  
Low water consumption.

## VERSATILITY

Make to order: customisation.  
OPL < > COIN (mod. DHS-11 up to DHS-45C).  
Electric < > Hot water.  
Drain valve < > Pump (DHS-11/14).  
Wet Cleaning features.

## CONNECTIVITY

IoT - **DOMUSCONNECT** standard.  
Remote technical service.  
Management for laundries: OPL and COIN.  
Remote payment DOMUS LAUNDRY App (mod. DHS-11 up to DHS-45C).

## ERGONOMICS

Easy opening/closing system for door lock.  
Biggest door diameters:
 

- Ø 373 (11, 14 kg)
- Ø 460 (18, 22, 28 kg)
- Ø 560 (35, 45, 60, 80 kg)
- Ø 700 (100, 120 kg)

## MAINTENANCE

Hinged control panel: easy and ergonomic access.  
Technical menu: statistics for technicians.

## OTHERS

Grey skinplate outer casing.  
Drum and vat in stainless steel AISI 304.  
Detergent dispenser with 4 compartments.  
Electronic control of imbalance with frequency control.  
LOADING AID feature: water and rotation control.  
Soft mounted washers, free standing.  
CB and WRAS approved product. Option ETL.  
REG4 standard certified by KIWA.



## OPTIONS

- License IoT - DOMUSCONNECT
- Ready for ECOTANK XL conn. 1" for washers DLS/DHS-60C/80C
- DOSING PUMP KIT DQ-2
- EXTRA DOSING PUMP DB-1
- Double drain kit for DHS-60C/80C
- Kit watermark Australia
- Normally closed valve DHS-60C/80C
- Double tilt for DHS-60C/80C - Available with weighing system
- Front tilt for DHS-60C/80C - Available with weighing system
- Water inlet hose for DHS-60C/80C (one per water intake)
- Weighing sensor system on feet for DHS-60C/80C/100C/120C - Available with tilt systems
- 6 extra dosing signals card for DHS-60C/80C/100C/120C
- Reversible door: reverse door opening
- Steam kit DHS-60C/80C
- Double heating E + S for DHS-60C/80C
- Stainless steel AISI 304 outer casing for DHS-60C
- 440V 3~ (No N) 50/60 Hz DHS-60C (marine)
- 230V 3~ 50/60Hz DHS-60C

TECHNICAL DATA	UNIT.	DHS-60C TOUCH II	
<b>DRUM</b>			
Load capacity 1:9 / 1:10	Kg	65/59	
Volume	l	590	
	gal	155,8	
Diameter	mm	1048	
	inch	41,2	
Depth	mm	680	
	inch	26,77	
<b>GENERAL DATA</b>			
Washing speed / Spin speed	r.p.m.	38/875	
G factor	-	450	
Maximum transmitted force	KN	18 ±4,2	
Dynamic force frequency	Hz	12,66	
Sound level	dB	< 70	
Self-service version	-	NO	
Double drain	-	OPT.	
Weighing system / Tilting system	-	OPT.	
SLUICE option	-	NO	
<b>DOOR</b>			
Door centre height / Door base height	mm	1170/810	
	inch	46"/31,88"	
Diameter	mm	560	
	inch	22"	
<b>POWER</b>			
Motor	kW	15	
Electric heating (electric model)	kW	36	
Maximum electric power	kW	39	
Max. power steam & hot water model	kW	15	
<b>CONNECTIONS</b>		<b>E</b>	<b>HW/S</b>
Voltage 110V - 1 + N + E	Nº x mm <sup>2</sup> / A	-	-
	Nº x AWG / A	-	-
Voltage 230V - 1 + N + E	Nº x mm <sup>2</sup> / A	-	-
	Nº x AWG / A	-	-
Voltage 230V - 3 + E	Nº x mm <sup>2</sup> / A	4x25 / 100A	4X6 / 40A
	Nº x AWG / A	4x3 / 125A	4x9 / 50A
Voltage 400V - 3 + N + E	Nº x mm <sup>2</sup> / A	5x16 / 63A	5x10 / 50A
	Nº x AWG / A	5x5 / 90A	5x7 / 30A
Steam inlet (steam model)	inch	3/4"	
Max. steam consumption (steam model)	Kg/h	21	
Water inlet	inch	1"	
Water pressure	Kgs/cm <sup>2</sup>	2-4	
Max. water consumption*	Lit/h	598	
	GPH	157,9	
Drain	mm/inch	3"	
Drain capacity	Lit/min	200	
	GPM	52,8	
<b>DIMENSIONS / PACKED DIMENSIONS</b>			
Net width / Gross width	mm	1.420/1.600	
	inch	55,9"/62,99"	
Net depth / Gross depth	mm	1.433/1.595	
	inch	56,4"/62,79"	
Net height / Gross height	mm	1.890/1.930	
	inch	74,4"/75,98"	
Net weight / Gross weight	kg	1.454/1.544	
	lb	3205,5/3403,9	

Packing volume	m3	4,9
	ft3	173

Programme no.20, 75% load

\*\*Programme no.2, 100% load

\*\*\* 400V version = 48kW / 230V = 36kW

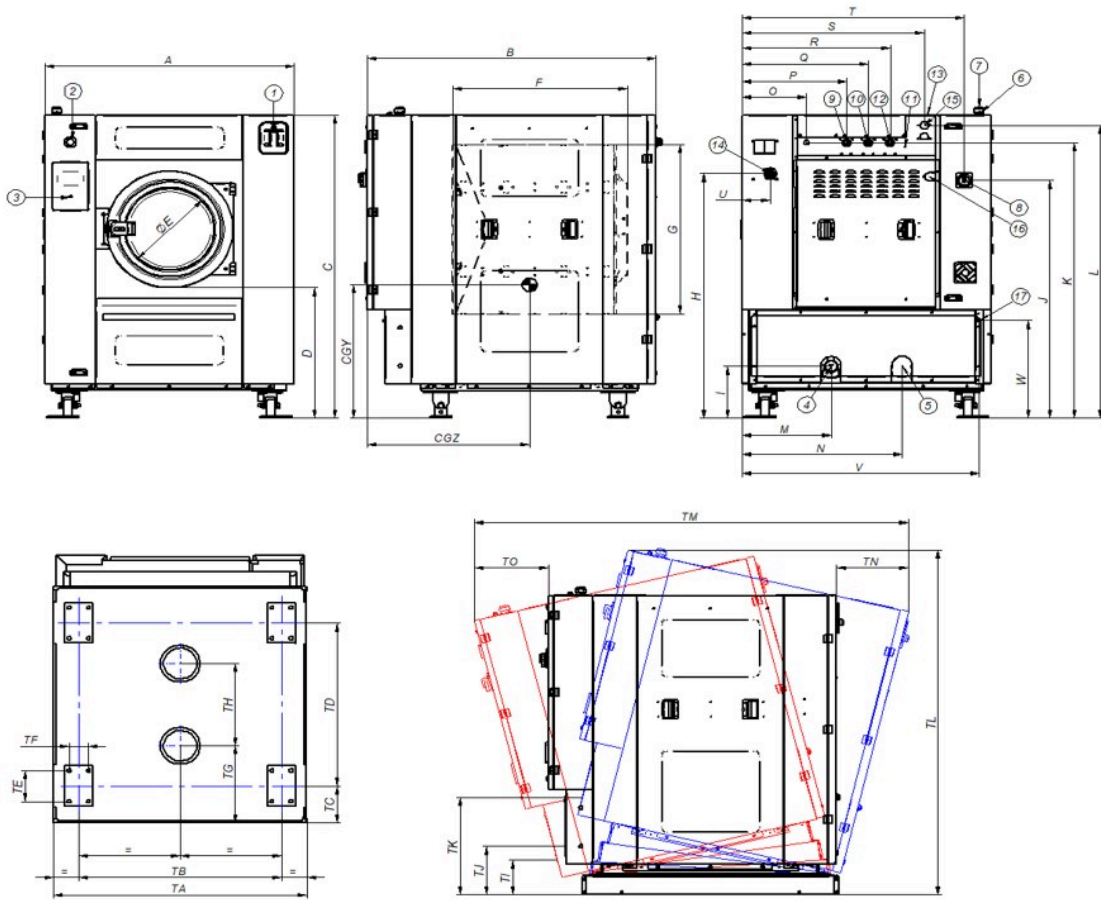

1. Soap dispenser
2. Emergency stop
3. USB port
4. Drain 1
5. Drain 2
6. Electric connection to liquid soap pumps
7. Electrical connection
8. Main switch
9. Auxiliar water inlet
10. Hot water inlet
11. Equipotential connection
12. Cold water inlet
13. Steam output
14. Liquid soap connection
15. Steam connection
16. Air intake
17. Ethernet port

		A	B	C	D	E	F	G	H	I	J	K	L	M	N	O	P	Q	R	S	T	U	V	W	X	Y	CGY	CGZ
DHS-60C	mm	1420	1433	1890	810	560	760	1050	1563	323	1475	1710	1817	508	912	367	595	720	845	1040	1267	160	1353	608	1500	348	830	820
DHS-80C	mm	1420	1645	1890	810	560	972	1050	1563	323	1475	1710	1817	508	912	367	595	720	845	1040	1267	160	1353	608	1500	348	830	925
		TA	TB	TC	TD	TE	TF	TG	TH	TI	TJ	TK	TL	TM	TN	TO												
DHS-60C	mm	1145	1157	226	799	190	110	265	722	215	300	565	2095	2266	410	422												
DHS-80C	mm	1145	1157	226	1011	190	110	475	510	215	300	602	2137	2478	410	422												