

TOUCH II

User friendly and totally programmable Touch II with 7" coloured touch screen.
 USB Connection. PC software free of charge for programming, tracability, data analysis, etc.
 Videos on display (ads, instructions, etc.)
 37 languages.

OUTSTANDING FEATURES

Reversing drum action as standard.
 Stainless steel drum as standard.
 Frequency inverter as standard.

EFFICIENCY

DOUBLE FLOW - Axial-radial airflow system.
 EFFICIENT DRY: Intelligent humidity detector.
 Big fluff filter.
 Double door glass.

VERSATILITY

Make to order - customisation
 Wet Cleaning.
 OPL > Multivending - Standard OPL model easily transformable to coin laundry uses.

CONNECTIVITY

IoT **DOMUSCONNECT**
 Laundry management: OPL and self-service
 Remote payment (self-service)

ERGONOMICS

Drawer as fluff filter, made of stainless steel.
 Biggest door diameters.
 Opening sense of door adjustable on site.

MAINTENANCE

Hinged panel: easy and ergonomic access.
 Technical menu: statistics, alarm, autotest, data recovery for technicians and maintenance.

OTHERS

Grey skinplate outer casing, stainless steel look.
 SOFT DRY - drum with stamped holes.
 COOL DOWN - anti-wrinkle at the end of the cycle.
 FULL GREEN FILTER: filter with larger surface area and improved air flow.
 No need of exhaust to the exterior.
 Low energy consumption.
 Water to refrigerate, which may be reused to wash.
 CE approved.



OPTIONS

- Free license IoT - DOMUSCONNECT
- Natural gas heated tumble dryer
- Opposite door opening
- Tropicalized model
- Stainless steel front and side panels DTT-23 HP
- Front panel in stainless steel DTT-23 HP
- Maritime wooden packing DTT-23 HP
- Several payment systems for self-service

TECHNICAL DATA	UNIT.	DTT-23 HP ECO-ENERGY
Capacity 1/18	Kg	26
Capacity 1/20	Kg	23
Capacity 1/30	Kg	15
Hourly Output*	Kg/h	22,9
Evaporation capacity*	l/h	11,5
DRUM		
Ø Drum	mm	855
Drum length	mm	800
Drum volume	l	460
Ø Loading door	mm	574
POWER		
Drum motor power	kW	0,37
Fan motor power	kW	0,55
Electric heating power ALL RANGES	kW	3,8 + 4***
Total electric power (elec. model)	kW	8,77
Electric consumption	** kWh/l	1,05
Nominal airflow	m ³ /h	1.200
CONNEXIONS		
Tension 400V - III + N + T (50 Hz)	Nº x mm ² / A	5 x 4 / 20
Heat pump inlet (cooling)	BSP	1/2"
Heat pump outlet (cooling)	BSP	1/2"
Drain	BSP	3/4"
DIMENSIONS / DIMENSIONS WITH PACKAGING		
Net width / Gross width	mm	890 / 970
Net depth / Gross depth	mm	1.590 / 1.720
Net height / Gross height	mm	1.812 / 1.940
Net weight / Gross weight	Kg	380 / 395
OTHERS		
Noise level	dB	64

* It may vary depending on the type of heating, filter cleanliness or extraction type

** kWh per litre of evaporated water

*** Compressor + resistances

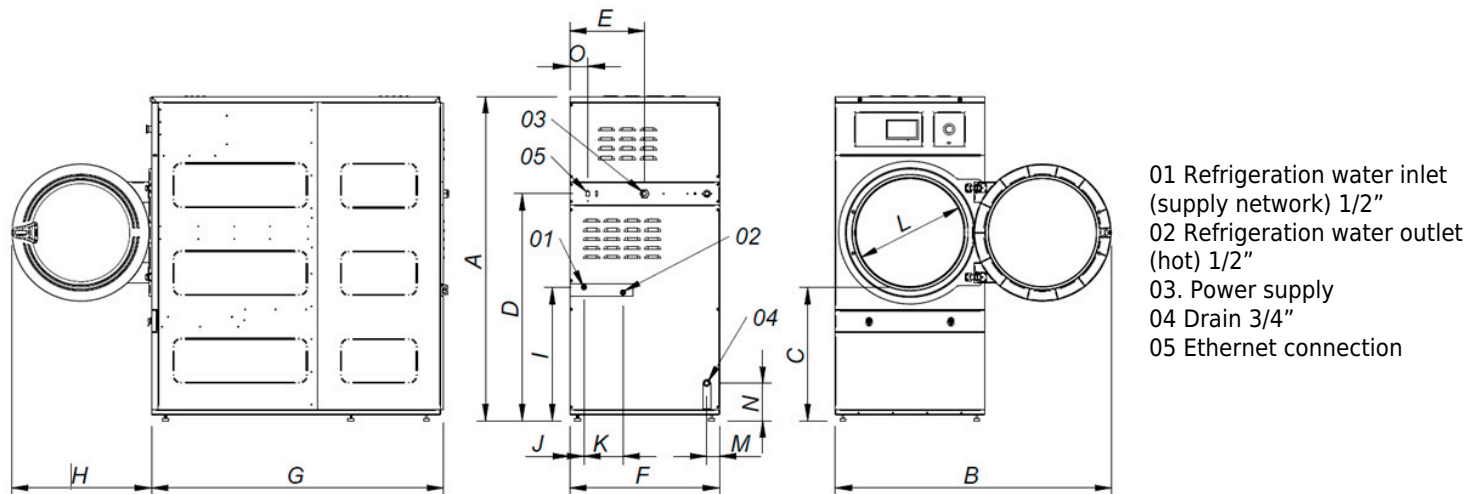

	A	B	C	D	E	F	G	H	I	J	K	L	M	N	O
DTT-11 HP ECO-ENERGY	1.694	1447	689	1190	392	785	1255	735	700	75	205	575	67	197	95
DTT-18 HP ECO-ENERGY	1.694	1447	689	1190	392	785	1525	735	700	75	205	575	67	197	95
DTT-23 HP ECO-ENERGY	1.812	1552	743	1190	445	890	1595	735	700	127	205	575	119	250	95