

### FEATURES

- Dries and irons flat linen. (NO folding or stacking).
- Can be equipped with an automatic feeder (optional), allowing a single operator to manage the feeding of items.
- Maximum output up to 290 kg/h.\*
- Adjustable ironing speed up to 18 m/min.\*
- Maximum temperature: 165°C.
- Automatic ironing speed control.
- Automatic cooling of the ironing roller.
- Available in one or two work lanes.
- Intuitive and programmable 7" touchscreen.
- Fume extraction system with automatic fan cleaning.
- Customisable with different accessories.

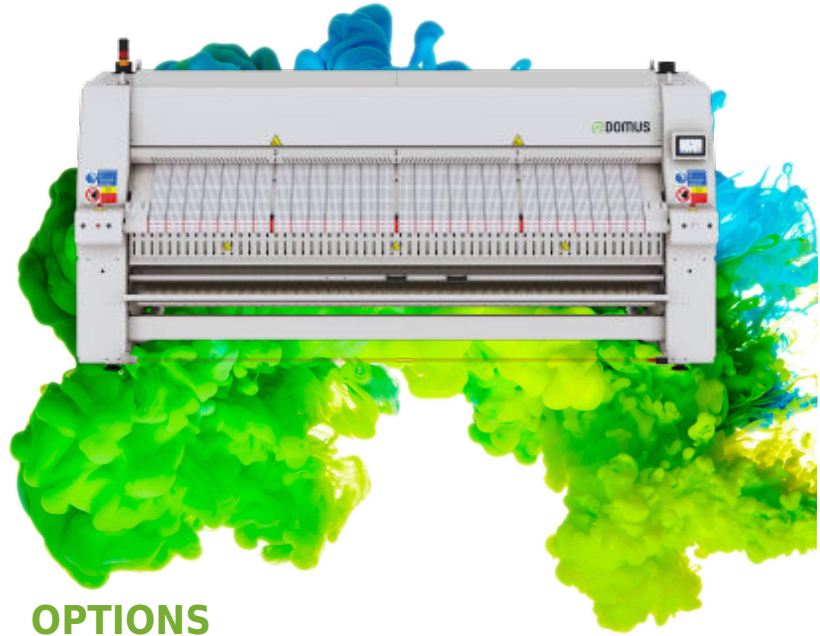

### OPTIONS

- Vacuum belts to help linen feeding
- Automatic 1 lane clamp feeder (needs option of vacuum feeding belts)
- Rear output with table (S600 H=850 mm, S800 H=800 mm. Bypass option required)
- Rear output with motorised table (H=870 mm. Bypass option required)
- Small pieces back collector: 2 lanes for S
- Small pieces back collector: 4 lanes for S
- Different voltage from 400V 3~ +N 50Hz
- Maritime packing for S

GENERAL DATA	UNIT.	S600-3300
Theoretical production elec/steam	Kg/h	110-140
Theoretical production gas heating*	Kg/h	110-140
Theoretical production radiant gas burner (+20%)*	Kg/h	132-168
Ø Roll	mm	600
Working width	mm	3.300
Height floor-feeding	mm	1.050
Working speed	m/min	3-12
Control type	-	Digital
No. of programs	Nº.	20
MAIN FUNCTIONS		
Drying	-	YES
Ironing	-	YES
Longitudinal folding	-	NO
Cross folding	-	NO
Lateral stacking (Roll-Off or compact stacker)	-	NO
FOLDING		
1 lane - lengthfold	Nº.	NO
1 lane - crossfold	Nº	NO
2 lanes - lengthfold	Nº	NO
2 lanes - crossfold	Nº	NO
4 lanes - lengthfold	Nº	NO
4+ lanes - folding	Nº	NO
POWER		
Electric model - Consumption	A	78
Electric model - Heating power	kW	54
Electric model - Total electrical power	kW	55,9
Steam model - Consumption	Kg/h	125
Steam model - Power (max 12 bar)	kW	75
Steam model - Total electrical power	kW	1,9
Liquefied gas (LPG) model - Consumption	m³/h	3,20
Liquefied gas (LPG) model - Power	kW	86,30
Natural gas (NG) model - Consumption	m³/h	8,50
Natural gas (NG) model - Power	kW	80,3
Gas LPG / NG model - Total electrical power	kW	1,9
CONNECTIONS		
Ø Gas inlet	BSP	1"
Ø Steam inlet (12 bar max.)	BSP	1"
Ø Condensed (steam models)	BSP	1/2"
Ø Air inlet	mm	12
DIMENSIONS		
Net width / gross width	mm	4.370 / 4.530
Net depth / gross depth	mm	1.440 / 1.620
Net height / gross height	mm	2.030 / 1.960
Net weight / gross weight	Kg	2.050 / 2.350
Volume	m³	12,77 / 14,38
OTHERS		
Exhaust outlet	Nº	2
Exhaust outlet Ø	mm	120
Air extraction flow rate	m³/h	2 x 630
Air consumption (6.5 bar)	NI/h	5.000
Noise level	dB	<80

\* 50% residual moisture, 140gr/m² of cotton, 100% roll use

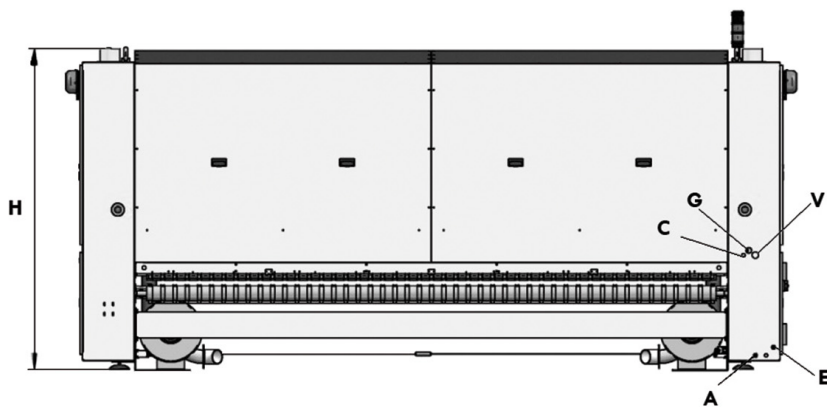

- A. Compressed air inlet
- C. Condensation discharge (steam models)
- E. Electrical connection
- F. Fumes extraction
- G. Gas inlet
- V. Steam inlet

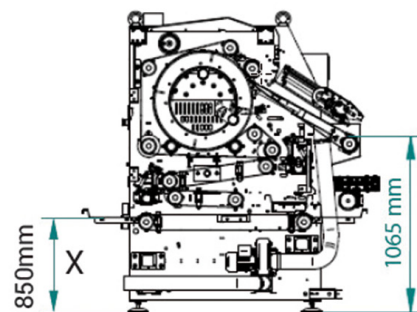
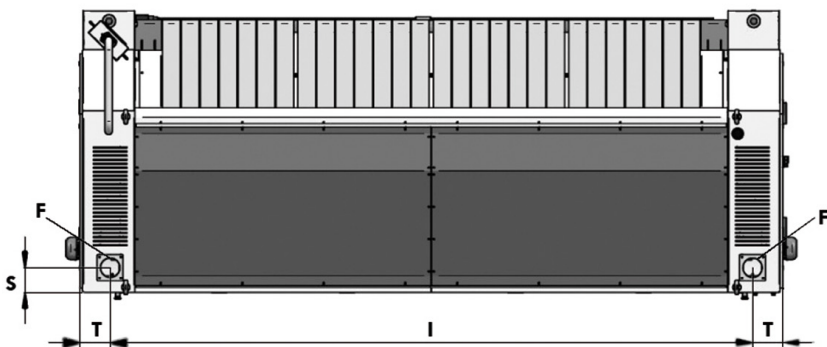

	H	I	T	S	A	C	E	F	G	V
<b>S600-2600</b>	1.800	3.242	186	152	Ø12	1/2"	5x2,5	Ø120	1"	1"
<b>S600-3300</b>	1.800	3.942	186	152	Ø12	1/2"	5x2,5	Ø120	1"	1"