

FEATURES

Roll sizes: 2.600 and 3.300mm wide and 600, 800 and 1.000mm de diameter.

Panels in painted steel.

Frequency control.

Feeding and ironing belts are NOMEX.

Touch-screen control: programs can be created with speed control (between 3 and 18 mts/min) and temperature.

Automatic stop after cooling down (at 80°C).

Big output capacity, depending on the residual moisture of the linen, up to 290 kg/hour straight from the high spin washer extrator.

Electric, gas or steam heating.

Gas models with radiant burner (increase of 25% more production, available in diametre 800 models and standard in diameter 1.000 models).

Powerful exhaust system.

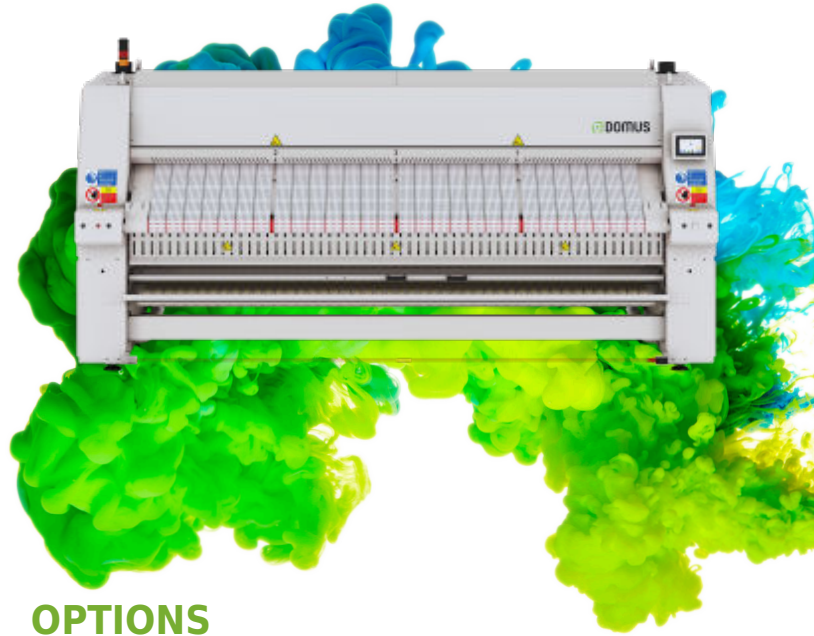

OPTIONS

- Vacuum table to help the linen feeding
- Automatic 1 lane clamp feeder without vacuum feeding belts
- Rear exit
- Motorized rear exit - height 860 mm. (rear exit included)
- Small pieces back collector: 2 lanes for S
- Small pieces back collector: 4 lanes for S
- Different voltage from 400V III +N 50Hz
- Maritime packing for S

GENERAL DATA	UNIT.	S800-2600
Theoretical production* elec/steam/atm. Gas heating	Kg/h	170
Theoretical production* radiant gas burner	Kg/h	195
Ø Roll	mm	800
Working width	mm	2.600
Height floor-feeding	mm	970
Working speed	mt/min	3-13
Control type	-	Digital
Nº of programs	Nº	20
POWER		
Electric heating	kW	72
Max. electric power electric heating	kW	74,2
Gas heating (natural / LPG)	kW	86,95 / 91,70
Max. electric power gas heating	kW	2,2
Steam heating	kW	85
Max. electric power steam heating	kW	2,2
CONNECTIONS		
Ø Gas inlet	BSP	1"
Ø Steam inlet (12 bar max.)	BSP	1"
Ø Condensed (steam models)	BSP	1/2"
Ø Air inlet	BSP	12
DIMENSIONS / PACKAGING DIMENSIONS		
Net width / gross width	mm	3.790 / 3.900
Net depth / gross depth	mm	1.770 / 2.280
Net height / gross height	mm	2.200 / 2.140
Net weight / gross weight	Kg	2.350 / 2.700
Volume	m ³	14,76 / 19,03
OTHERS		
No. Fume outlet	Nº	2
Ø Fume outlet	mm	160
Extraction rate	m ³ /h	2 x 1.000
Compressed air consumption (6,5 bar)	mm	5.000
Sound Level	dB	70

* 50% residual moisture, 140gr/m² of cotton, 100% roll utilization

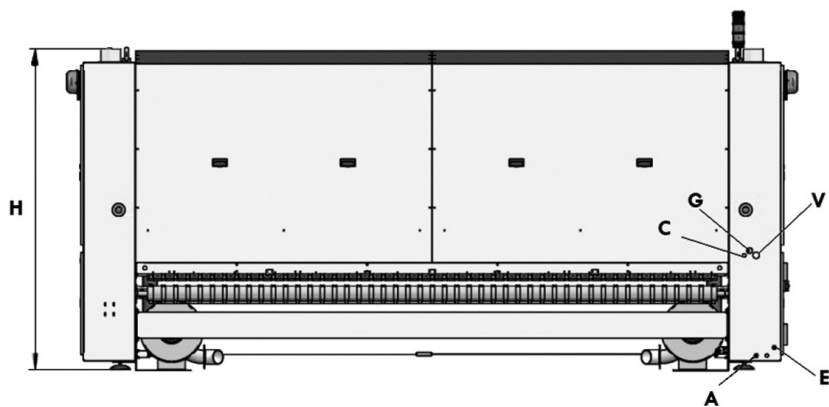

- A. Compressed air inlet
- C. Condensation discharge (steam models)
- E. Electrical connection
- F. Fumes extraction
- G. Gas inlet
- V. Steam inlet

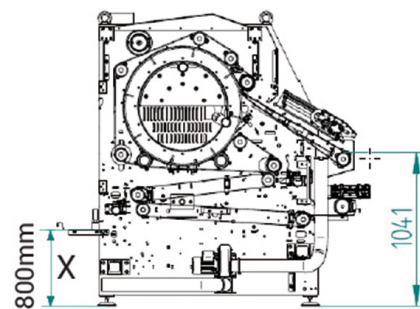
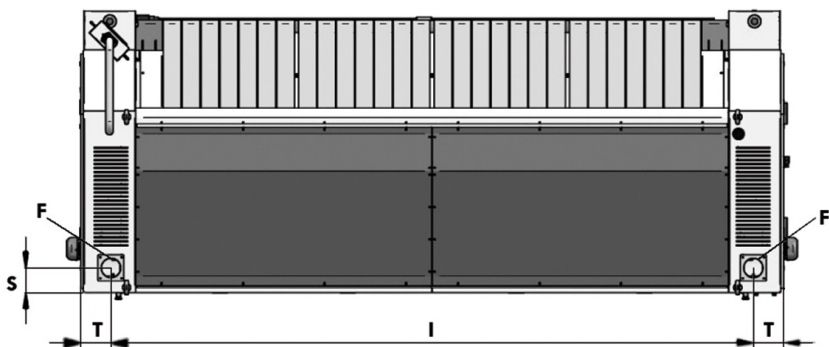

	H	I	T	S	A	C	E	F	G	V
S800-2600	1.966	3.242	186	152	Ø12	1/2"	5x2,5	Ø120	1"	1"
S800-3300	1.966	3.942	186	152	Ø12	1/2"	5x2,5	Ø120	1"	1"