

FEATURES

DOMUS finishing cabins are compact steam finishing units designed to remove wrinkles and shape entire garments using mannequins, providing a fast and professional finish even in small spaces.

Common features:

- Easy to use and compact in size, ideal for installation in small premises.
- Finishing is achieved with minimal steam loss, improving comfort and workplace safety.
- Modular system allowing two trouser mannequins or two upper mannequins, depending on requirements.
- Automatic cycle, adjustable via three timers.
- Intuitive control with the ability to program up to 9 automatic programs.

BOX model:

No boiler, requires external steam supply.

BOX-C model:

Autonomous version with integrated automatic electric boiler.

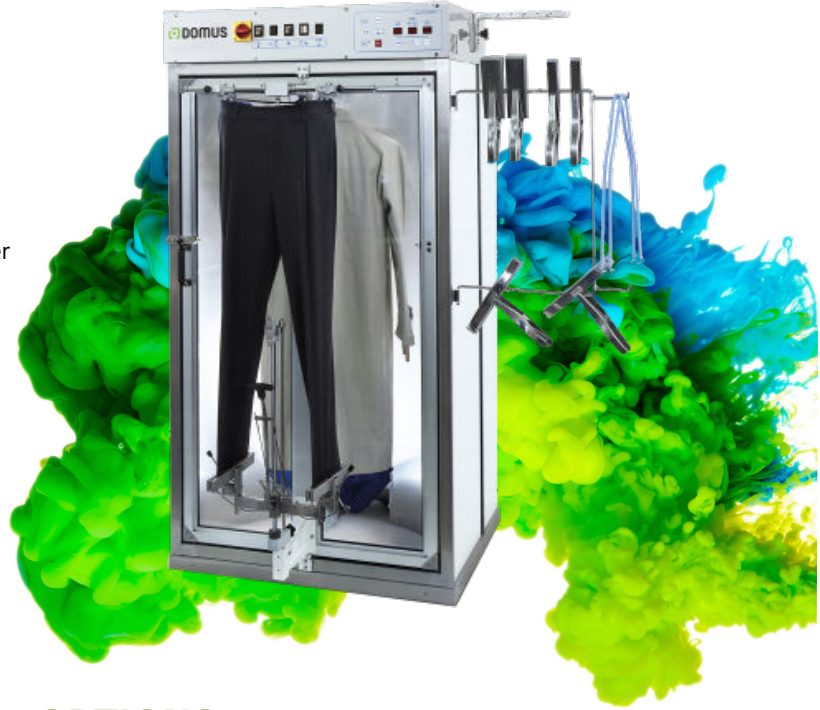

OPTIONS

- Leg stretcher

GENERAL DETAILS	UNIT.	BOX
Boiler	-	NO
Boiler capacity	L	-
POWER		
Pump motor	HP	-
Compressor motor	kW	15
Boiler heater	kW	-
Fan motor	kW	1-1,5
CONNECTIONS		
Ø Water inlet	BSP	-
Ø Boiler exhaust (mod. with boiler)	BSP	-
Ø Steam inlet	BSP	1/2"
Boiler drain	BSP	-
Steam pressure	BAR	-
Steam consumption	Kg/h	16-20
Ø Air inlet	BSP	1/4"
Ø Air outlet	mm	140
Air pressure	BSP	4-5
Air Consumption	NI/min	6
NET DIMENSIONS / PACKING DIMENSIONS		
Net width / Gross width	mm	1.080 / 1.080
Net depth / Gross depth	mm	1.375 / 1.190
Net height / Gross height	mm	1.850 / 2.020
Net weight / Gross weight	Kg	180 / 248
Volume	m ³	2,75 / 2,60
OTHERS		
Voltage	V/Hz	230/400V III 50-60
Sound level	dB	65

BOX A

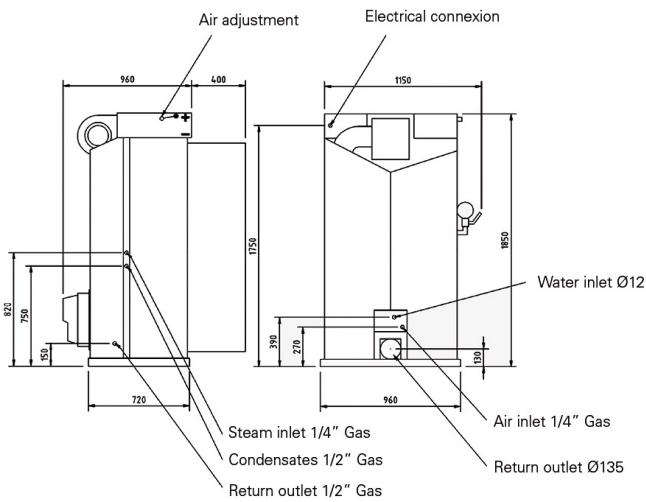

BOX C

