

## TOUCH II

7" touch screen easy to use and fully programmable, display on dirty side.  
Screen on both sides of the machine.  
Connection USB. Free software online for programming, telemetry, data analysis, etc.  
37 languages.  
8 dosing signals as standard.

## OUTSTANDING FEATURES

Automatic positioning of drum.  
2 water inlets.  
Wet Cleaning, telemetry as standard.  
G FACTOR 350.  
Dual heating electric - steam model - energy savings.

## EFFICIENCY

Intelligent consumption: automatic adjustment of water and soap consumptions (standard).  
Optimal loading: manual indication of weight.  
Water Recovery tanks ready: **ECOTANK**  
Low water consumption.  
High G FACTOR: reduced residual moisture > reduced drying time.

## CONNECTIVITY

IoT - **DOMUSCONNECT** standard  
Remote technical service.  
Management of laundries.

## ERGONOMICS

Huge door opening making loading/unloading easier.  
User-friendly drum opening by push button.  
Loading height: door base 670 mm.

## MAINTENANCE

Electric components on the left side, mechanical components on the right side and connections on the top (protected from water and detergents).  
Central drain as standard.  
Technical menu: statistics, alarms, autotest, data recovery for technicians and maintenance.

## OTHERS

2 opposed doors. Pass-through barrier washer.  
Ready to be connected to dosing pumps.  
Grey skinplate outer casing.  
Drum and vat in stainless steel AISI 304.  
Frequency inverter to control imbalance.  
CE approved product



## OPTIONS

- License IoT - DOMUSCONNECT
- Ready for ECOTANK conn. 3/4" for barriers ASM-16
- Model with a single door ASM-16
- 7" second screen on clean side
- Weighing system on feet. Includes kit with 6 extra dosing signals.
- 6 extra dosing signals card for liquid dosing. Total of 14 signals.
- 3rd water inlet
- 2nd drain valve
- Titration valve
- Side drain valve
- Low steam pressure battery (0,5 bar)
- 4 compartment detergent box ASM-16
- Electric drum motor brake
- UPS option (in case of power failure)
- End of cycle light alarm
- Plinth for ASM-16 to align loading height (door base at 850 mm)
- Stainless steel AISI 304 outer casing for ASM-16
- Stainless steel frame ASM-16
- Stainless steel frame ASM-16 equipped with loading base
- Maritime wooden packing for ASM-16
- 440V III No N 50/60Hz (maritime)

DRUM	UNIT.	ASM-16 TOUCH II	
Load capacity 1:9	Kg	18	
	lb	39,7	
Load capacity 1:10	Kg	16	
	lb	35,3	
Volume	l	158	
	ft <sup>3</sup>	5,58	
Diameter	mm	633	
	inch	24,9	
Depth	mm	500	
	inch	19,7	
Drum compartments	Nº	1	
GENERAL DETAILS			
Washing speed	rpm	45	
Spining speed	rpm	1.000	
G Factor	-	350	
TOUCH II Control	-	7"	
Double screen	-	OPT	
Motor break	-	OPT	
Double drainage	-	OPT	
DOOR			
Drum opening dimensions	mm	400 x 315	
	inch	15,7 x 12,4	
Vat opening dimensions	mm	455 x 415	
	inch	17,9 x 16,3	
Height door bottom	mm	670	
	inch	26,4	
POWER			
Motor	kW	2,20	
Electric heating (elec. mod)	kW	12	
Total electric power (elec. mod)	kW	14,20	
Total electric power (steam mod)	kW	2,20	
CONNECTIONS		E/DUAL	S
Tension 230V I + N + T 50/60Hz	Nº x mm <sup>2</sup> /A	-	3 x 1,5 / 6A
Tension 230V III + T 50/60Hz	Nº x mm <sup>2</sup> /A	4 x 10 / 40A	-
Tension 400V III + N + T 50/60Hz	Nº x mm <sup>2</sup> /A	5 x 6 / 25A	-
Water inlets number	-	2 (3)	
Water inlet	inch	3/4"	
Water pressure	bar	3 - 5	
	psi	43 - 72	
Steam inlet (steam mod)	inch	3/4"	
Steam pressure	bar	4-8	
	psi	58-116	
Drain number	-	1	
Drain evacuation capacity	l/min	160	
	cfm	5,65	
Drain	inch	3"	
OVERALL DIMENSIONS			
Net / Gross width	mm	1.056 / 1.072	
	inch	38,7 / 42,2	
Net / Gross depth	mm	1.082 / 1.102	
	inch	42,60 / 43,4	
Net / Gross height	mm	1.382 (1.426) / 1.530	
	inch	54,41 (56,14) / 60,2	
Net / Gross weight	kg	438 / 459	
	lb	966 / 1.011,9	

Volume	m <sup>3</sup>	1,81
	ft <sup>3</sup>	63,8

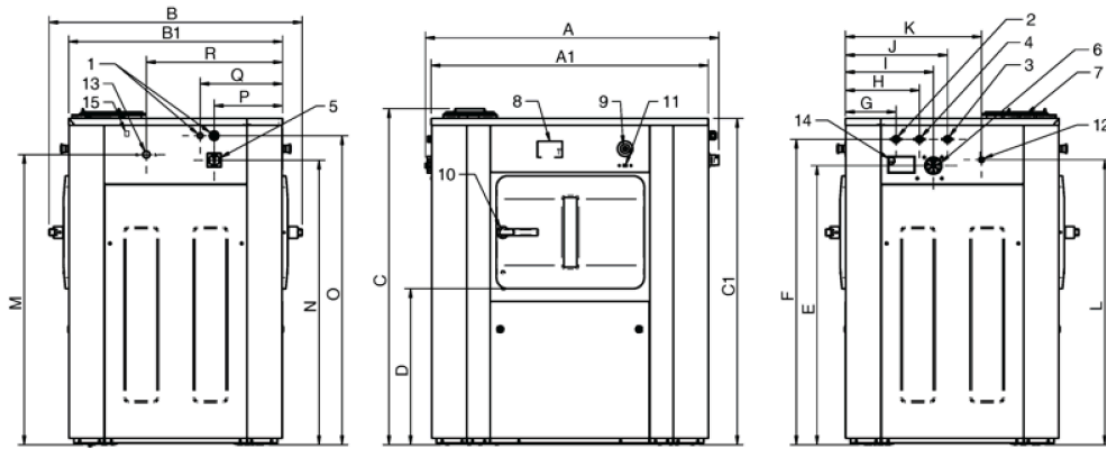

1. Electrical connexion
2. Hot water
3. Cold water
4. Soft water
5. Main Switch
6. Liquid products inlet
7. Detergent box (option)
8. Control panel
9. Emergency stop
10. Door opening
11. USB port
12. Dosing pumps connexion
13. Steam inlet
14. Exhaust
15. Ethernet port

	A	B	C	A1	B1	C1	D	E	F	G	H	I	J	K	L	M	N	O	P	Q	R
ASM-16	1.054	1.082	1.426	984	914	1.385	661	1.184	1.296	217	317	377	437	582	1.209	1.231	1.207	1.311	292	352	582
ASM-22	1.254	1.082	1.426	1.184	914	1.385	661	1.184	1.296	217	317	377	437	582	1.209	1.231	1.207	1.311	292	352	582